

Proposal Basic Information	
Proposal File No.	MADA/BP/0237/2024
Owner Name	SRI PAPPU KUMAR
Khata No	11 (OLD), 220 (NEW)
Plot No	728 (OLD), 515 (NEW)
Village Name	Amaghata
Use	Residential
SubUse	Bungalow/ Dwelling / Non Apartment

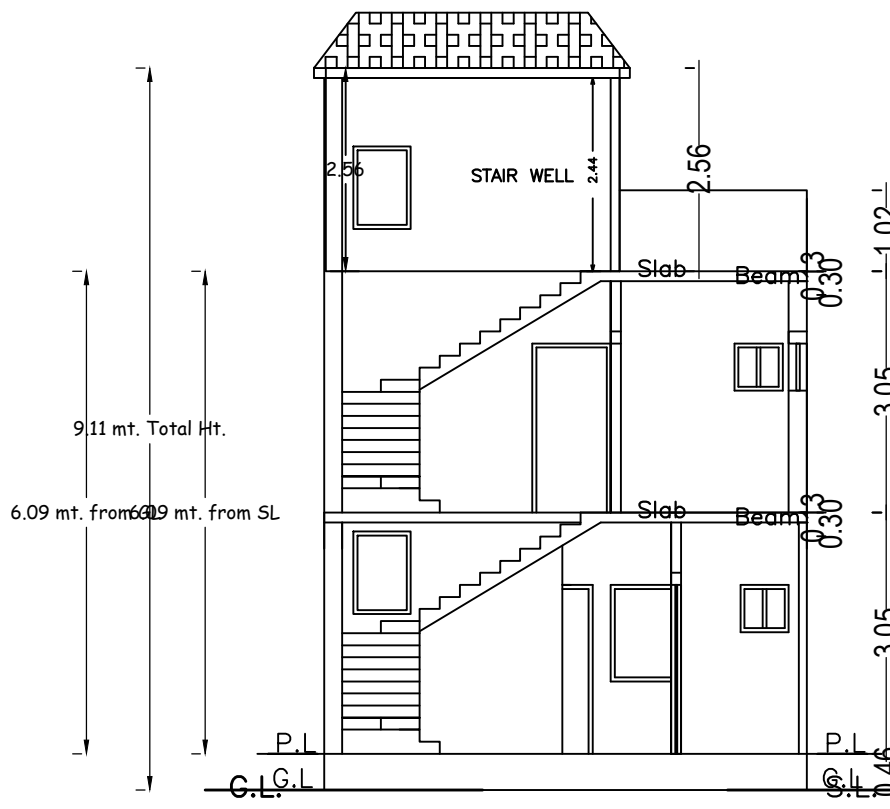

SECTION AT X-X

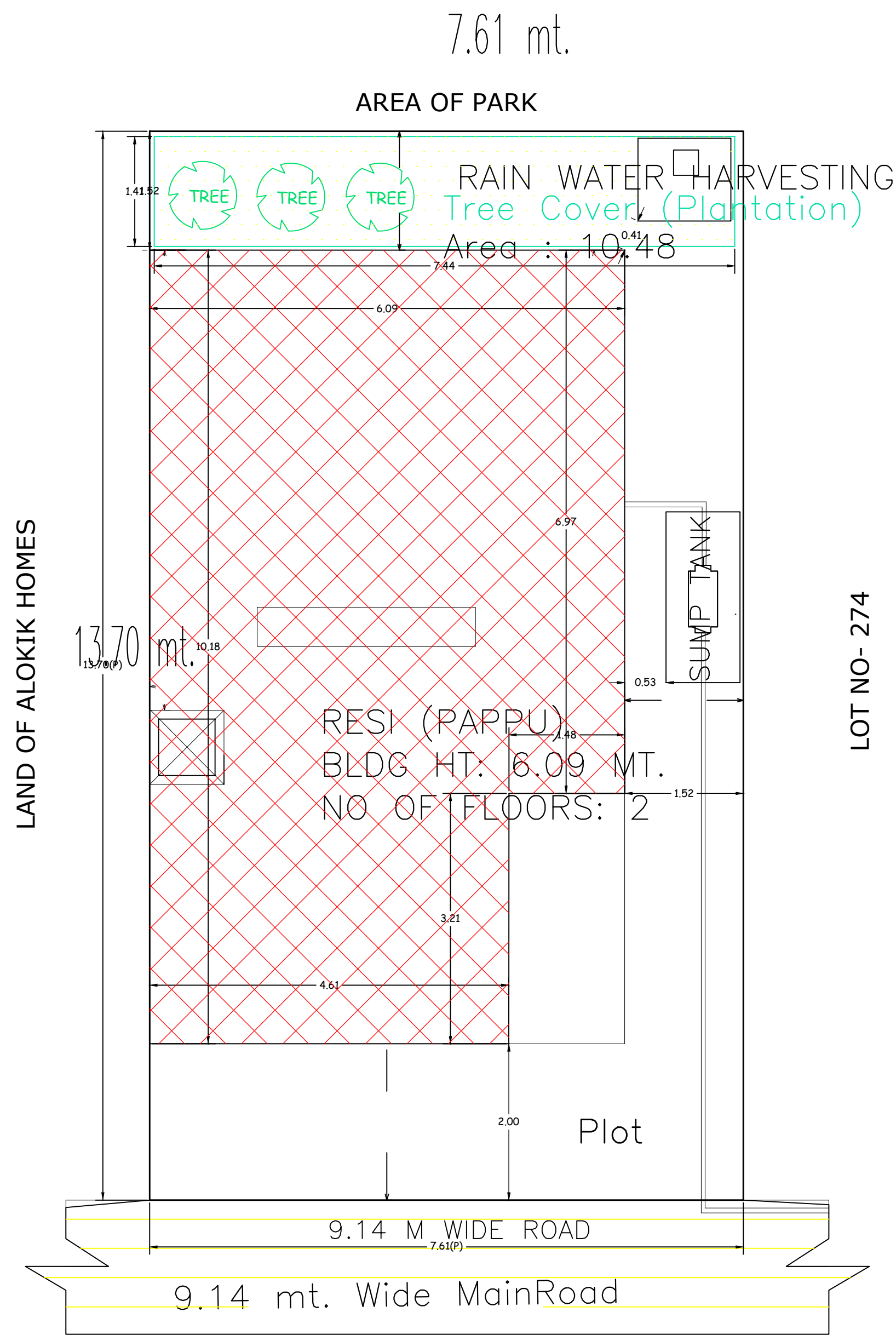
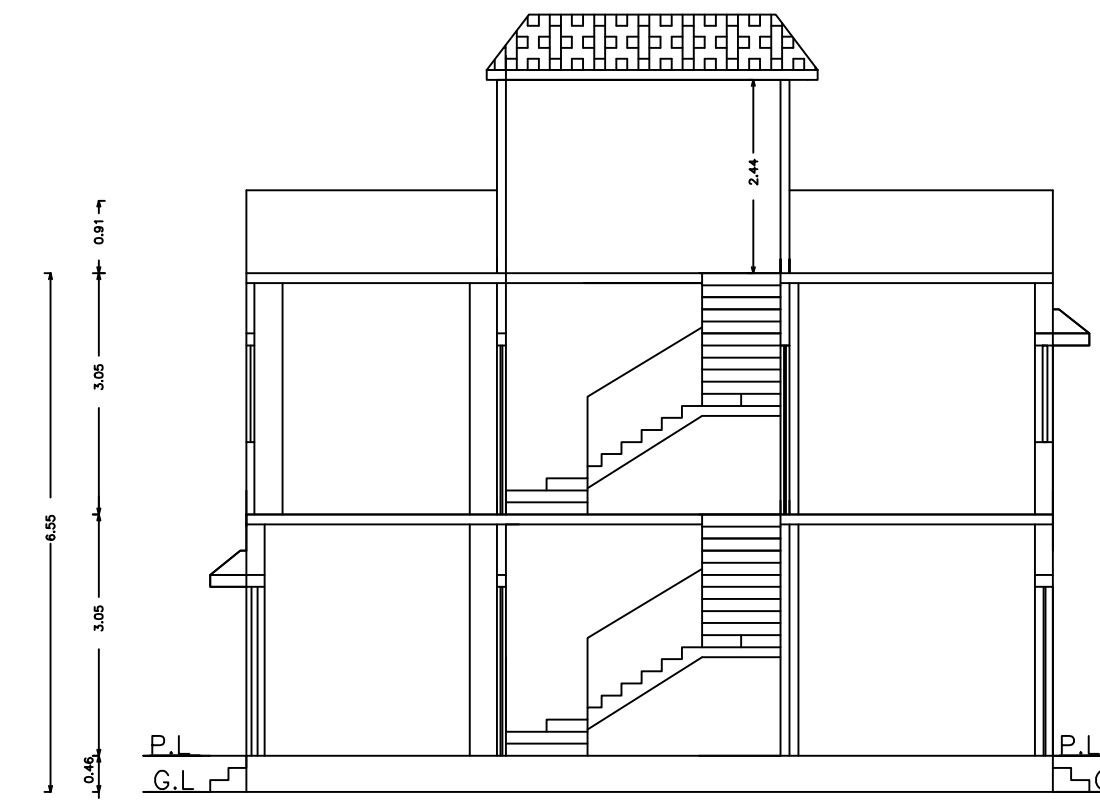

SECTION AT Y-Y

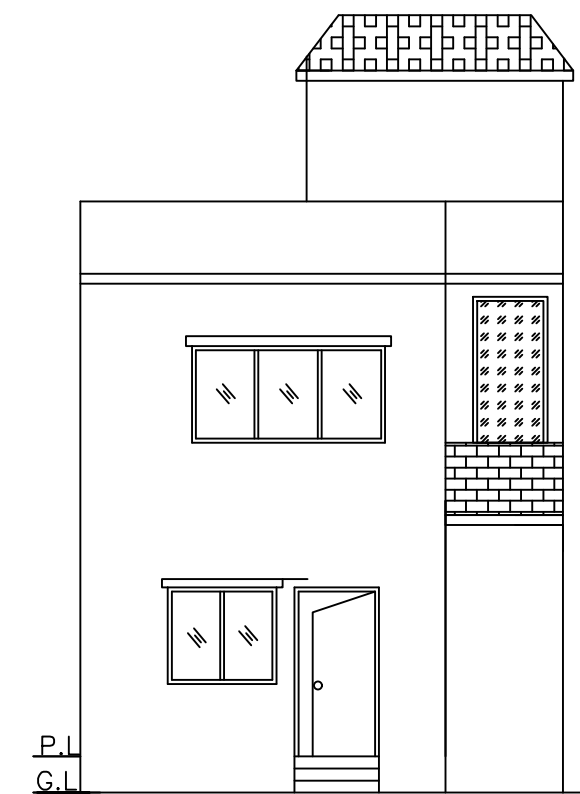

FRONT ELEVATION

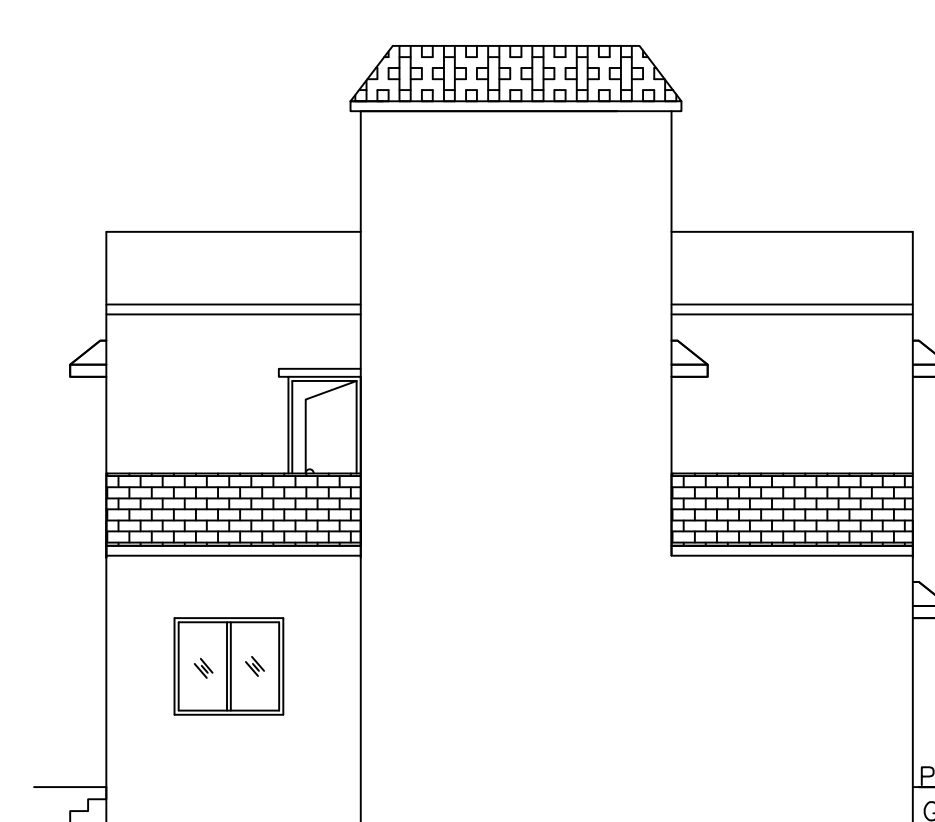

RIGHT SIDE ELEVATION

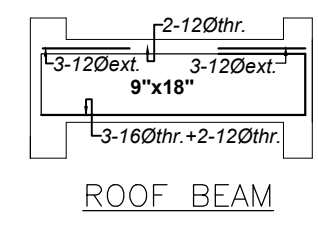
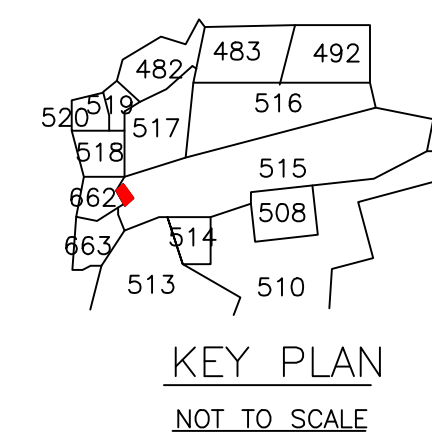

ROOF BEAM

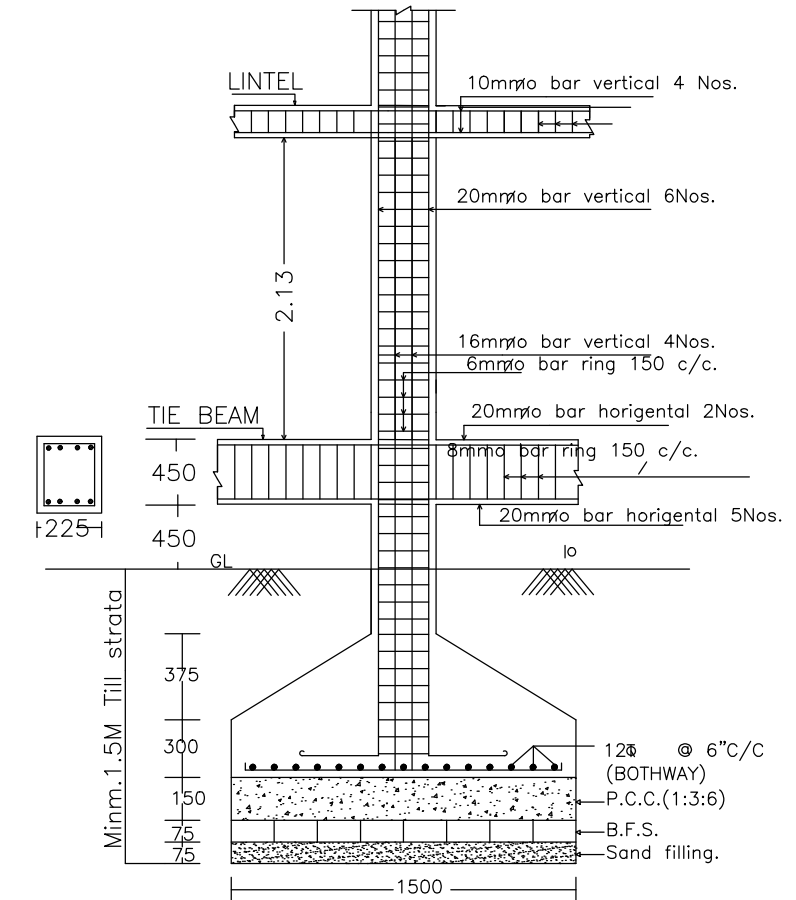

DETAIL OF COLUMNS

SCALE:- 1:25

UnitBUA Table for Building :RESI (PAPPU)

FLOOR	Name	UnitBUA Type	UnitBUA Area	Carpet Area	No. of Rooms	No. of Tenement
GROUND FLOOR PLAN	SPLIT 1	FLAT	103.54	103.50	5	1
FIRST FLOOR PLAN	SPLIT 1	FLAT	0.00	0.00	5	0
Total:	-	-	103.54	103.50	10	1

SCHEDULE OF DOOR:

BUILDING NAME	NAME	LENGTH	HEIGHT	NOS
RESI (PAPPU)	D	0.84	2.10	04
RESI (PAPPU)	D	0.94	2.10	01
RESI (PAPPU)	D	0.99	2.10	03
RESI (PAPPU)	D	1.07	2.10	01
RESI (PAPPU)	D	1.17	2.10	01
RESI (PAPPU)	D	1.37	2.10	01

SCHEDULE OF WINDOW/VENTILATION:

BUILDING NAME	NAME	LENGTH	HEIGHT	NOS
RESI (PAPPU)	W	0.61	1.20	04
RESI (PAPPU)	W	0.99	1.20	01
RESI (PAPPU)	W	1.03	1.20	01
RESI (PAPPU)	W	1.26	1.20	01
RESI (PAPPU)	W	1.52	1.20	03
RESI (PAPPU)	W	2.44	1.20	01

Building :RESI (PAPPU)

Floor Name	Gross Builtup Area	Deductions From Gross BUA/Area in Sq.m.)	Total Built Up Area (Sq.m.)	Proposed FAR Area (Sq.m.)	Total FAR Area (Sq.m.)	Total Consumed Additional FAR Area (Sq.m.)	Trmt (No.)
Ground Floor	57.22	0.52	56.70	56.70	56.70	56.70	01
First Floor	49.92	3.07	46.85	46.85	46.85	46.85	00
Terrace Floor	0.00	0.00	0.00	0.00	0.00	0.00	00
Total :	107.14	3.59	103.55	103.55	103.55	103.55	01
Total Number of Same Buildings	1						
Total :	107.14	3.59	103.55	103.55	103.55	103.55	01

AREA STATEMENT MINERAL AREA DEVELOPMENT AUTHORITY		VERSION NO.: 1.0.70	VERSION DATE: 16/10/2020
PROJECT DETAIL:			
Region: JHARKHAND URBAN LOCAL BODIES	Plot Use: Residential		
District: DHANBAD	Plot SubUse: Bungalow/ Dwelling / Non Apartment		
Authority: MINERAL AREA DEVELOPMENT AUTHORITY	PlotNearbyReligiousStructure: NA		
Inward No: MADA/BP/0237/2024	Plot/SubPlot No: 728 (OLD), 515 (NEW)		
Application Type: General Proposal	North: Plot No. - LOT NO-274		
Project Type: Building Permission	South: Plot No. - LAND OF ALOKIK HOMES		
Nature of Development: New	East: Road Width - 9.14		
Location of Development Area: Old Area	West: Plot No. - AREA OF PARK		
AREA DETAILS:			
AREA OF PLOT (Minimum)	(A)		SQ.MT. 104.34
NET AREA OF PLOT (Gross Plot Area - Deduction from Gross Plot area)	(A-Deductions)		104.34
Deduction for Balance Plot Area (from Gross Plot Area)			
Common Plot			10.48
Total			10.48
BALANCE AREA OF PLOT (Net Plot Area - Recreational/Amenity space)	(A-Deductions)		93.86
PLOT AREA FOR COVERAGE (Net Plot Area)	(A-Deductions)		104.34
Plot Area for FAR (Net Plot Area + Road Widening Area)	(A-Deductions)		104.34
COVERAGE CHECK			
Permissible Coverage area (70.00 %)			73.04
Proposed Coverage Area (54.34 %)			56.70
Total Prop. Coverage Area (54.34 %)			56.70
Balance coverage area (15.66 %)			16.34
FAR CHECK			
Perm. FAR Area (2.500)			260.85
Total Perm. FAR area			260.85
Residential FAR			103.54
Proposed FAR Area			103.54
Total Proposed FAR Area			103.54
Consumed FAR (Factor)			0.99
Balance FAR Area			157.31
BUILT UP AREA CHECK			
Total Proposed BuiltUp Area			103.55
ARCHITECT (Regd)		ANIL KUMAR CHAUDHARY	
ENGINEER (Regd)			
SUPERVISOR (Regd)		SRI PAPPU KUMAR	
OWNER (Regd)			
DEVELOPMENT AUTHORITY		LOCAL BODY	



Buildingwise Floor FAR Details

Floor Name	Building Name		Total	
	Proposed Built Up Area (Sq.m.)	Proposed FAR Area (Sq.m.)	Total Proposed Built Up Area (Sq.m.)	Total FAR Area (Sq.m.)
Ground Floor	56.70	56.70	56.70	56.70
First Floor	46.85	46.85	46.85	46.85
Terrace Floor	0.00	0.00	0.00	0.00
Total :	103.55	103.55	103.55	103.55

Building USE/SUBUSE Details

Building Name	Building Use	Building SubUse	Building Structure
RESI (PAPPU)	Residential	Bungalow/ Dwelling / Non Apartment	Non-Highrise

FAR & Tenement Details (Table 4c-1)

Building	No. of Same Bldg	Gross Built Up Area (Sq.m.)	Deductions From Gross BUA/Area in Sq.m.)	Total Built Up Area (Sq.m.)	Proposed FAR Area (Sq.m.)	Total FAR Area (Sq.m.)	Total Consumed Additional FAR Area (Sq.m.)	Trmt (No.)
RESI (PAPPU)	1	107.14	3.59	103.55	103.55	103.55	103.55	01
Grand Total :	1	107.14	3.59	103.55	103.55	103.55	103.55	01

SITE PLAN

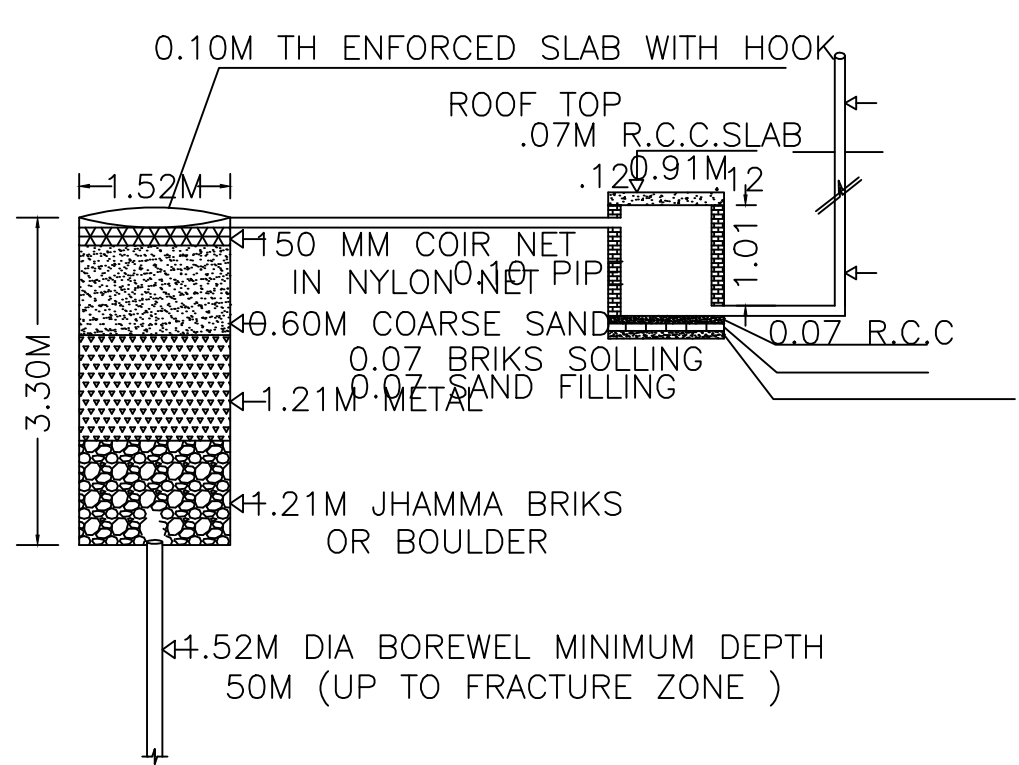

DETAIL OF GROUND WATER RECHARGING PIT WITH SILT TANK NOT TO SCALE

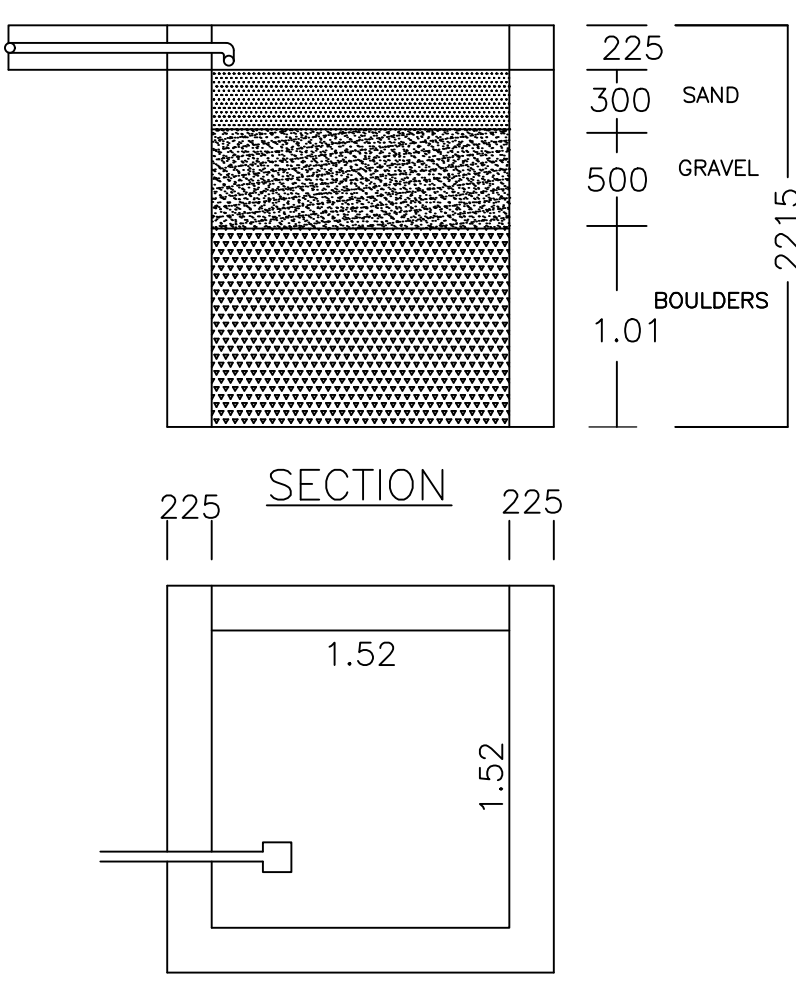

PLAN OF RAIN WATER HARVESTING (SCALE:- 1:25)

