

Project Title :RANJU DEVI

AREA STATEMENT MINERAL AREA DEVELOPMENT AUTHORITY		VERSION NO. 1.0.37			
PROJECT TITLE	PROJECT NO.	VERSION DATE: 16/10/2020			
Township No. :	Plot Use: Residential				
Region : JHARKHAND URBAN LOCAL BODIES	Plot Location: Bungalow Dwelling / Non Apartment				
TOWN: GOVINDPUR	Land Use Zone: Residential				
Application Type: General Proposal	Abutting Road Width:				
Project Type: Existing Renovation	Fig No.:				
Nature of Development: New	Revenue Survey No/Survey No.:				
Location: Old Area	Thana No.:				
Soil Category: HA	PSNO No.:				
Village/Mouza Name:	Khata No.:				
Work No.:	North:				
Road/Street:	South:				
	East:				
	West:				
AREA DETAILS		Sq.Mt			
Area of Plot (Minimum)	(A)	118.11			
Net Plot Area (Gross Plot Area)	(A-Deductions)	118.11			
Deductions from Gross Plot Area					
Deductions for Balance Plot Area (from Gross Plot Area)					
COP Area		7.71			
Plot Area		7.71			
Balance Plot Area (Net Plot Area)	(A-Deductions)	110.40			
Proposed Building Spread					
Plot Area for Coverage (Net Plot Area)	(A-Deductions)	118.11			
Plot Area for FSI (Net Plot Area + Equatorial Area)	(A-Deductions)	118.11			
Proposed Coverage Area (60.43%)		71.37			
FSI Coverage Area (60.43%)		71.37			
FAR CHECK					
Proposed Area of FAR		142.74			
Permitted Area of FAR		142.74			
Total Area of FAR		142.74			
MULTI-FLOOR CHECK					
Net Proposed Building Area		142.74			
ANDH ENGRG. SUPERVISOR (Regd)	OWNER				
DEVELOPMENT AUTHORITY	LOCAL BODY				
COLOR INDEX					
Plot Boundary					
Abutting Road					
Proposed Work (Coverage Area)					
Existing (To be retained)					
Existing (To be demolished)					
Color Index					
MARGIN DETAIL:					
Building / Wing	Road Name	Front Margin	Rear Margin	Side Margin	Side Margin
A (A)	8.70 M MAIN ROAD	2.13	1.60	0.90	0.90
FAR & Tenement Details (Table 4c-1)					
Building	No. of Same Bldg.	Total Built Up Area (Sq.Mt.)	Total FAR Area (Sq.Mt.)	Tent (No.)	
A (A)	1	142.74	142.74	01	
Grand Total	1	142.74	142.74	01	

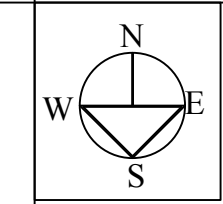
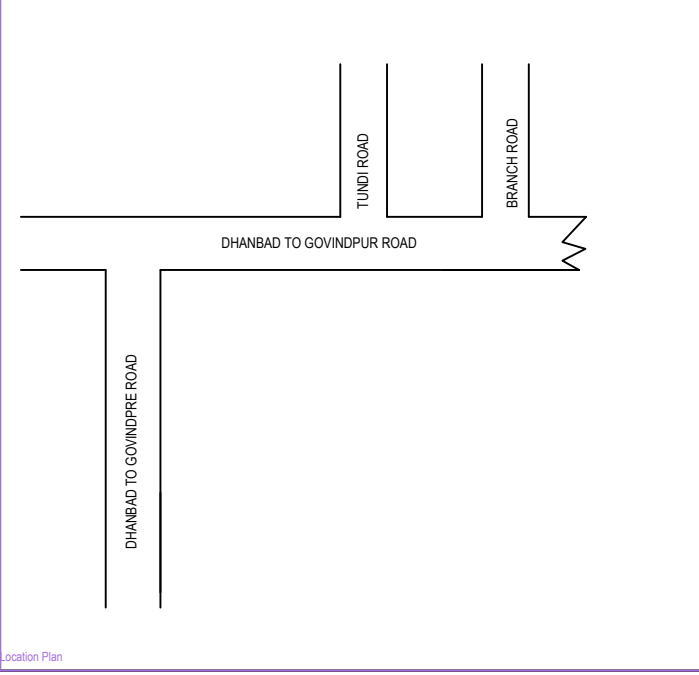
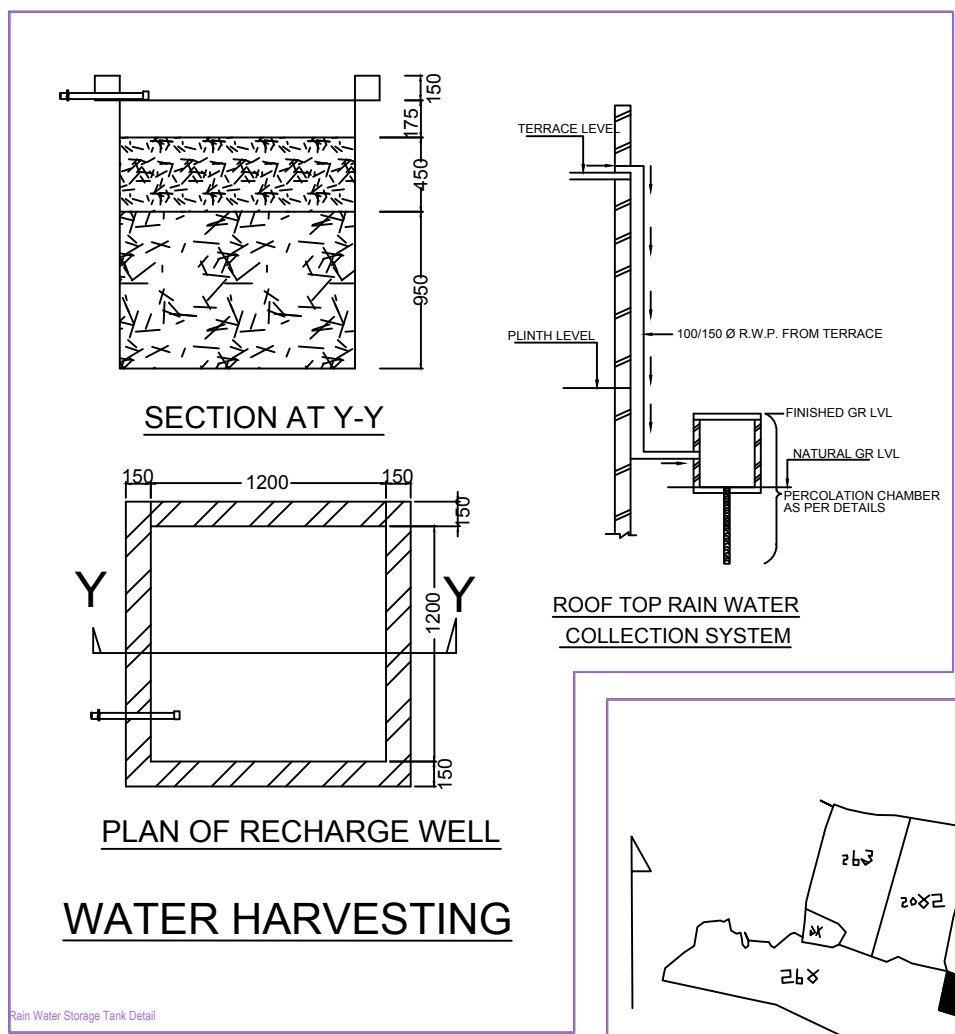
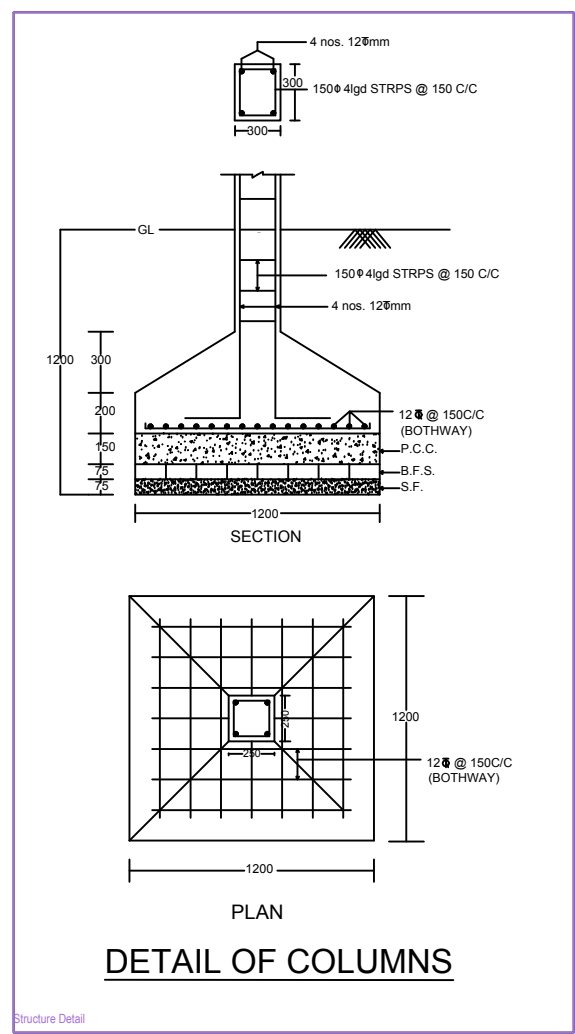
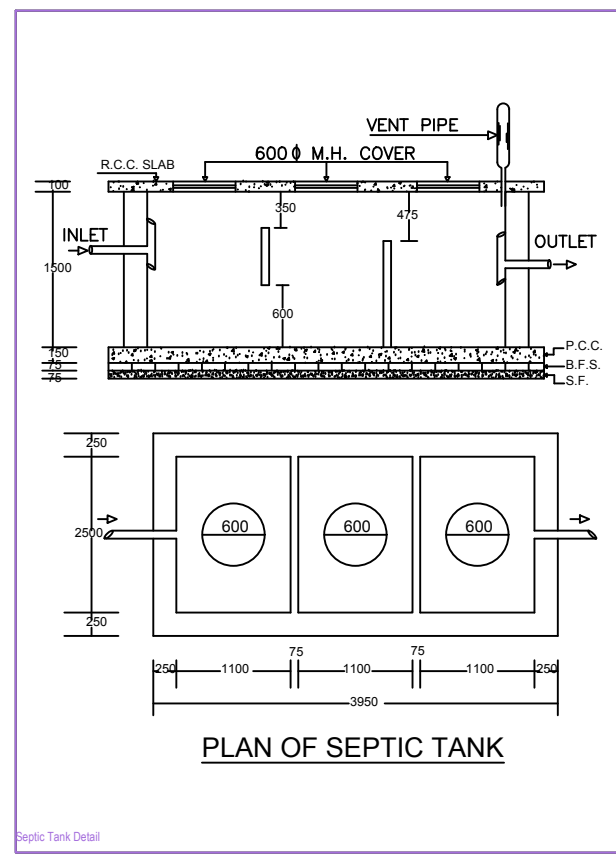
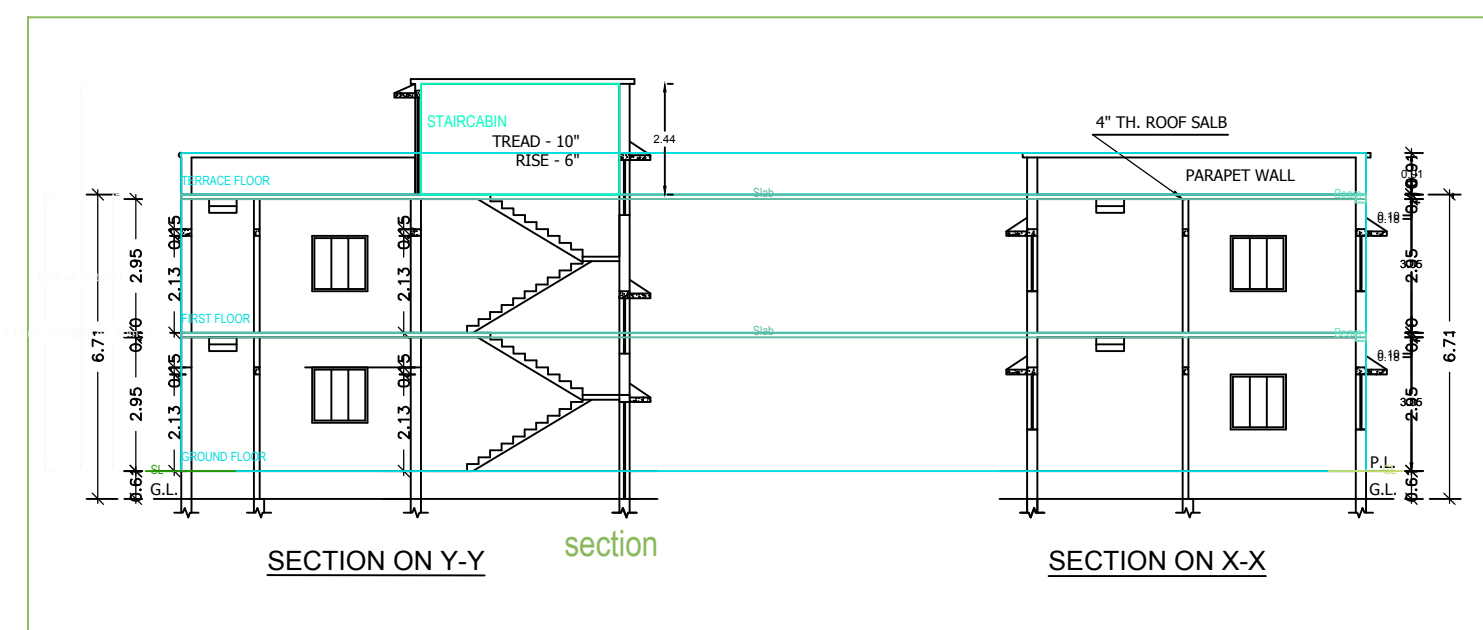
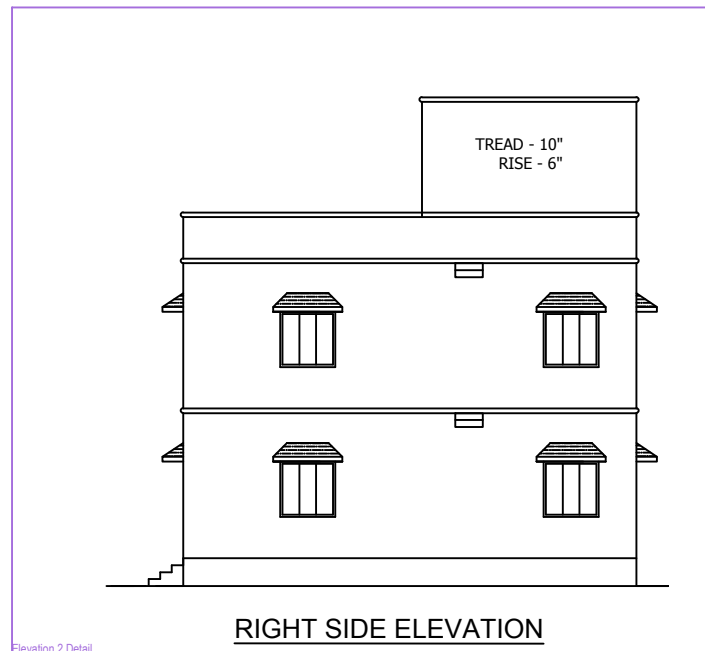
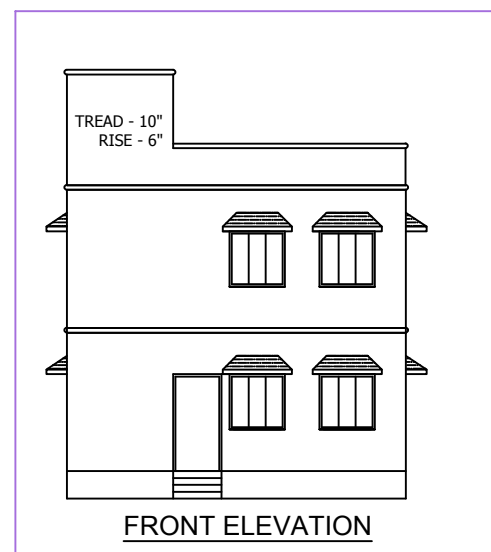

**BRIEF SPECIFICATION**  
 FOUNDATION----- CEMENT CONCRETE (1:1.5:3)  
 BRICK WORK IN FOUNDATION & SUPERSTRUCTURE  
 FIRST CLASS BRICK WORK IN CEMENT MORTAR (1:6)  
 D.P.C.-----25 D.P.C. IN CEMENT CONCRETE (1:2:4)  
 FLOOR-----25 I.P.S. OVER 75 P.C.C.  
 ROOF-----100 THK. R.C.C. ROOF (1:1.5:3)  
 LINTEL-----150 THK. R.C.C. LINTEL (1:1.5:3)  
 STAIRS-----RISE-150, TREAD-250

**DETAILS OF AREA**

TOTAL AREA (AS PER DEED)	121.42 SQM.
TOTAL AREA (AS PER SITE)	118.11 SQM.
GROUND FLOOR AREA	71.37 SQM.
FIRST FLOOR AREA	71.37 SQM.
TOTAL COVERED AREA	142.72 SQM.
% PLINTH AREA	60.43 %
FAR	1.26

**SCHEDULE**

D = 1.500X2.100	W = 1.800X1.200
D1 = 1.050X2.100	V = 0.600X0.600
D2 = 0.900X2.100	

**TITLE OF DRAWING**  
 PLAN OF PROPOSED RESIDENTIAL BUILDING OF SMT. RANJU DEVI W/O SRI. CHANDRIKA MAHTO R/O NEAR BASTAKOLA COLLIERY NEAR OFFICE P.S. JHARIYA & DIST DHANBAD . MOUZA GOVINDPUR NO 166 NEW KHATA NO.-360 . OLD KHATA NO.-15 . NEW PLOT NO -2412,2413,2414 . OLD PLOT NO - 874 DIST. OF DHANBAD (JHARKHAND).

SIGNATURE OF OWNER

SIGNATURE OF ENGINEER

SCALE ALL DIMENSION ARE IN METRE

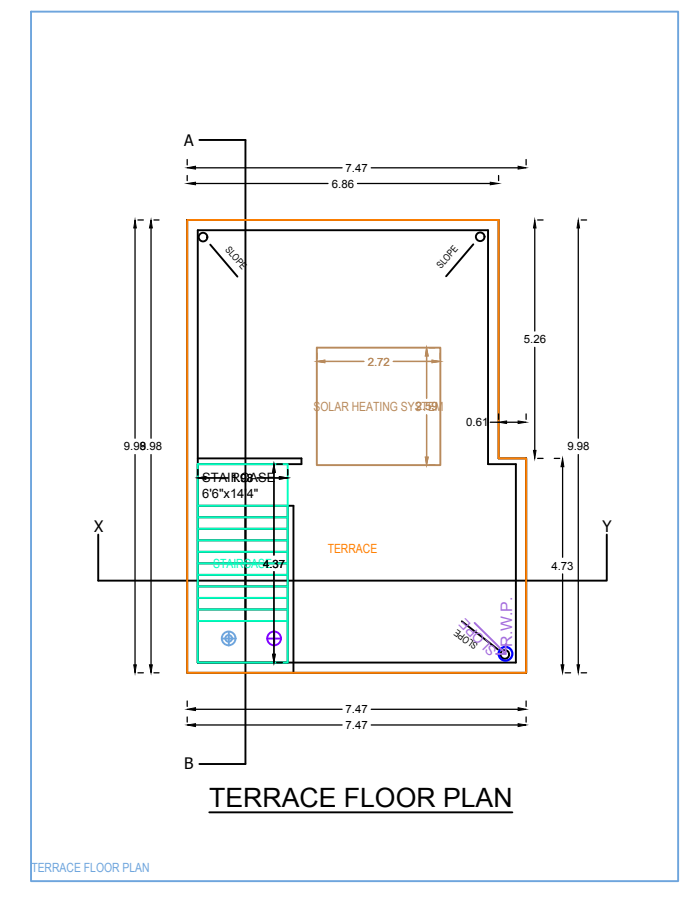
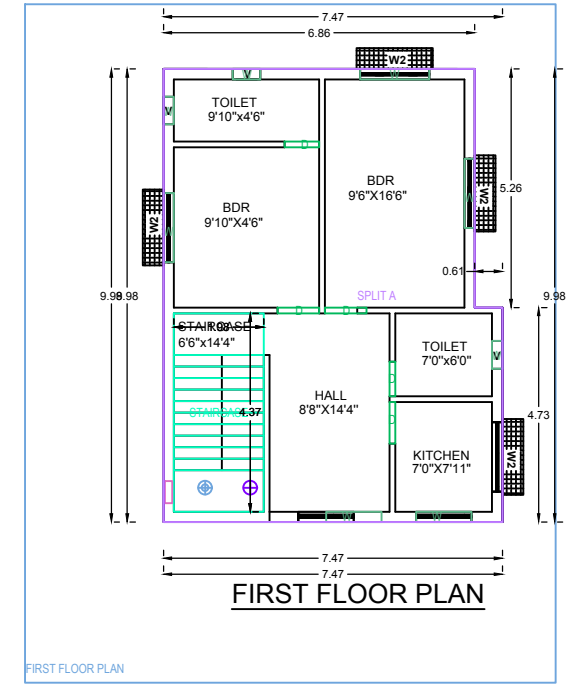
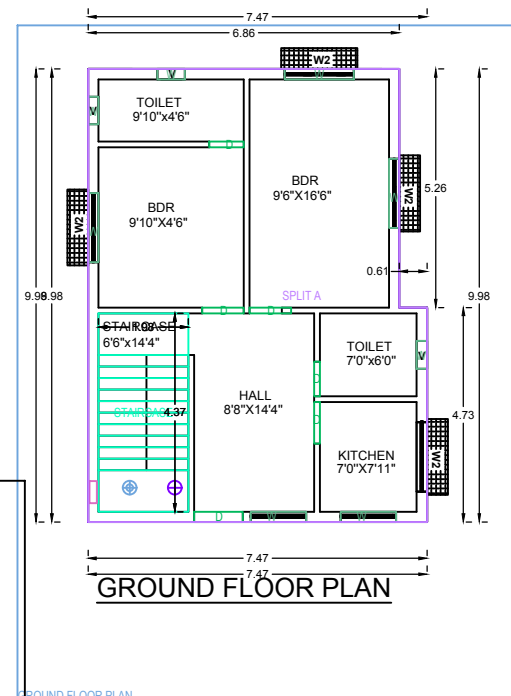
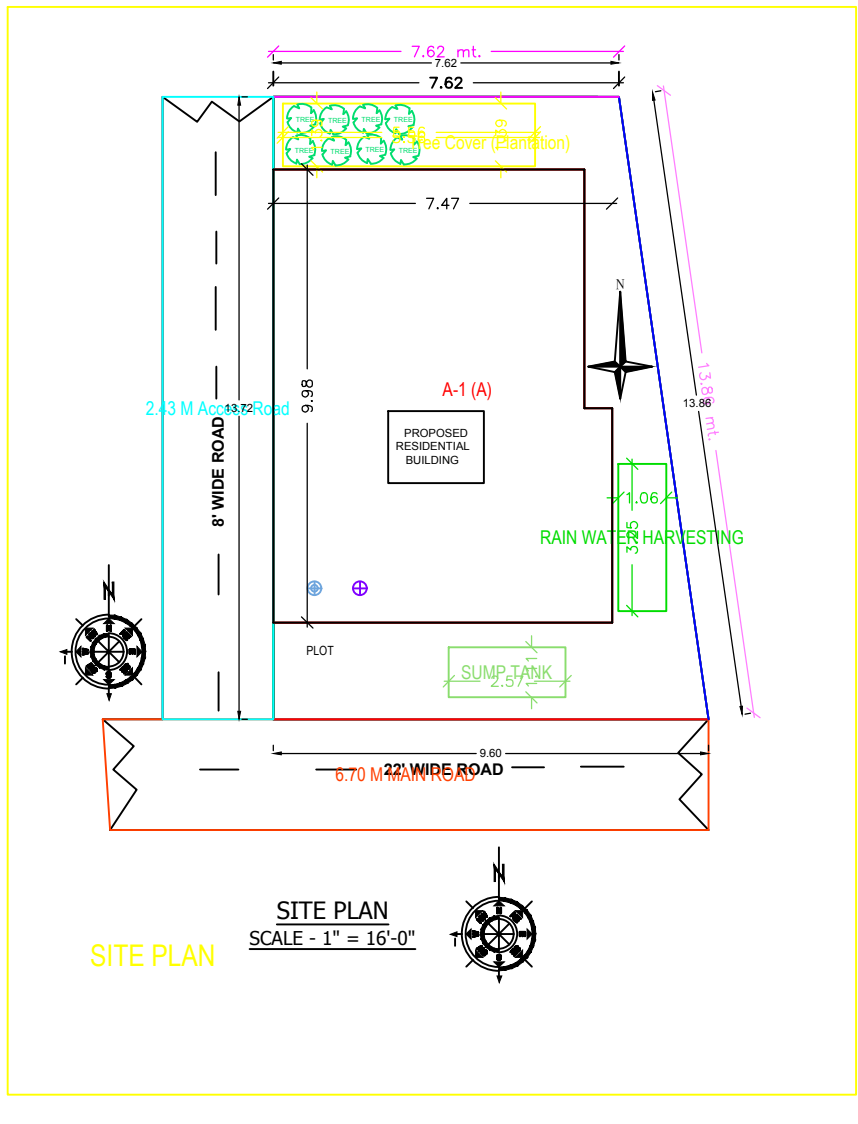

**Building A (A)**

Floor Name	Total Built Up Area (Sq.Mt.)	Proposed FAR Area (Sq.Mt.)	Total FAR Area (Sq.Mt.)	Tent (No.)
Ground Floor	71.37	71.37	71.37	01
First Floor	71.37	71.37	71.37	01
Terrace Floor	0.00	0.00	0.00	00
Total	142.74	142.74	142.74	01
Total Number of Same Buildings	1			
Total	142.74	142.74	142.74	01

**SCHEDULE OF JOINERY:**

BUILDING NAME	NAME	LENGTH	HEIGHT	NOS
A (A)	D	0.78	2.10	06
A (A)	D	0.91	2.10	06
A (A)	D	1.01	2.10	07
Total				11

**SCHEDULE OF JOINERY:**

BUILDING NAME	NAME	LENGTH	HEIGHT	NOS
A (A)	W	0.81	1.20	06
A (A)	W	1.22	1.20	06
A (A)	W	1.52	1.20	06
Total				18

**Unit/BUA Table for Building A (A)**

FLOOR	Name	UNIT/BUA TYPE	Unit/BUA Area	Proposed Area	No. of Rooms	No. of Tenement
GROUND FLOOR	SPLIT A	FLAT	142.74	142.58	6	1
Total			142.74	142.58	12	1