

Proposal Basic Information

Proposal File No.	MADA/BP/0179/2024
Owner Name	SMT SUSHMA SHARMA
Khata No	NEW- 357, OLD 33
Plot No	NEW- 510,511, OLD 555
Village Name	Merah
Use	Residential
SubUse	Bungalow Dwelling / Non Apartment

AREA STATEMENT MINERAL AREA DEVELOPMENT AUTHORITY	VERSION NO.: 1.0.70 VERSION DATE: 16/10/2020
PROJECT DETAIL:	
Region: JHARKHAND URBAN LOCAL BODIES	Plot Use: Residential
District: DHANBAD	Plot SubUse: Bungalow Dwelling / Non Apartment
Authority: MINERAL AREA DEVELOPMENT AUTHORITY	PlotNearby/ReligiousStructure: NA
Inward No: MADA/BP/0179/2024	Plot/SubPlot No: NEW- 510,511, OLD 555
Application Type: General Proposal	North: Plot No. - VENDOR OWN
Project Type: Building Permission	South: Plot No. - VENDOR OWN
Nature of Development: New	East: Road Width - 5.48
Location of Development Area: Old Area	West: Plot No. - VENDOR OWN
AREA DETAILS:	SQ.MT.
AREA OF PLOT (Minimum)	(A) 140.73
NET AREA OF PLOT(Gross Plot Area - Deduction from Gross Plot area)	(A-Deductions) 140.73
Deduction for Balance Plot Area(from Gross Plot Area)	
Common Plot	24.43
Total	24.43
BALANCE AREA OF PLOT(Net Plot Area - Recreational/Amenity space)	(A-Deductions) 116.30
PLOT AREA FOR COVERAGE(Net Plot Area)	(A-Deductions) 140.73
Plot Area for FAR (Net Plot Area + RoadWidening Area)	(A-Deductions) 140.73
COVERAGE CHECK	
Permissible Coverage area (70.00 %)	98.51
Proposed Coverage Area (57.60 %)	81.06
Total Prop. Coverage Area (57.6 %)	81.06
Balance coverage area (12.40 %)	17.45
FAR CHECK	
Perm. FAR Area (1.800)	253.31
Total Perm. FAR area	253.31
Residential FAR	139.07
Proposed FAR Area	139.07
Total Proposed FAR Area	139.07
Consumed FAR (Factor)	0.99
Balance FAR Area	114.24
BUILT UP AREA CHECK	
Total Proposed BuiltUp Area	162.12
ARCHITECT (Regd)	RAJEEV.RANJAN SINGH
ENGINEER (Regd)	
SUPERVISOR (Regd)	
OWNER (Regd)	SMT SUSHMA SHARMA
DEVELOPMENT AUTHORITY	LOCAL BODY

COLOR INDEX	
PLOT BOUNDARY	Black
ABUTTING ROAD	Red
PROPOSED CONSTRUCTION	Green
COMMON PLOT	Yellow
ROAD WIDENING AREA	Blue
EXISTING (To be retained)	Light Blue
EXISTING (To be demolished)	White

Buildingwise Floor FAR Details

Floor Name	Building Name		Total	
	Proposed Built Up Area (Sq.mt.)	Proposed FAR Area (Sq.mt.)	Total Proposed Built Up Area (Sq.mt.)	Total FAR Area (Sq.mt.)
Ground Floor	81.06	58.01	81.06	58.01
First Floor	81.06	81.06	81.06	81.06
Terrace Floor	0.00	0.00	0.00	0.00
Total :	162.12	139.07	162.12	139.07

Building USE/SUBUSE Details

Building Name	Building Use	Building SubUse	Building Structure
AA (B1)	Residential	Bungalow Dwelling / Non Apartment	Non-Highrise

FAR & Tenement Details (Table 4c-1)

Building	No. of Same Bldg	Total Built Up Area (Sq.mt.)	Deductions (Area in Sq.mt.)		Proposed FAR Area (Sq.mt.)	Total FAR Area (Sq.mt.)	Total Consumed Additional FAR Area (Sq.mt.)	Trnmt (No.)
			Accessory Use	Resi.				
AA (B1)	1	162.12	23.05	139.07	139.07	139.07	139.07	01
Grand Total :	1	162.12	23.05	139.07	139.07	139.07	139.07	01

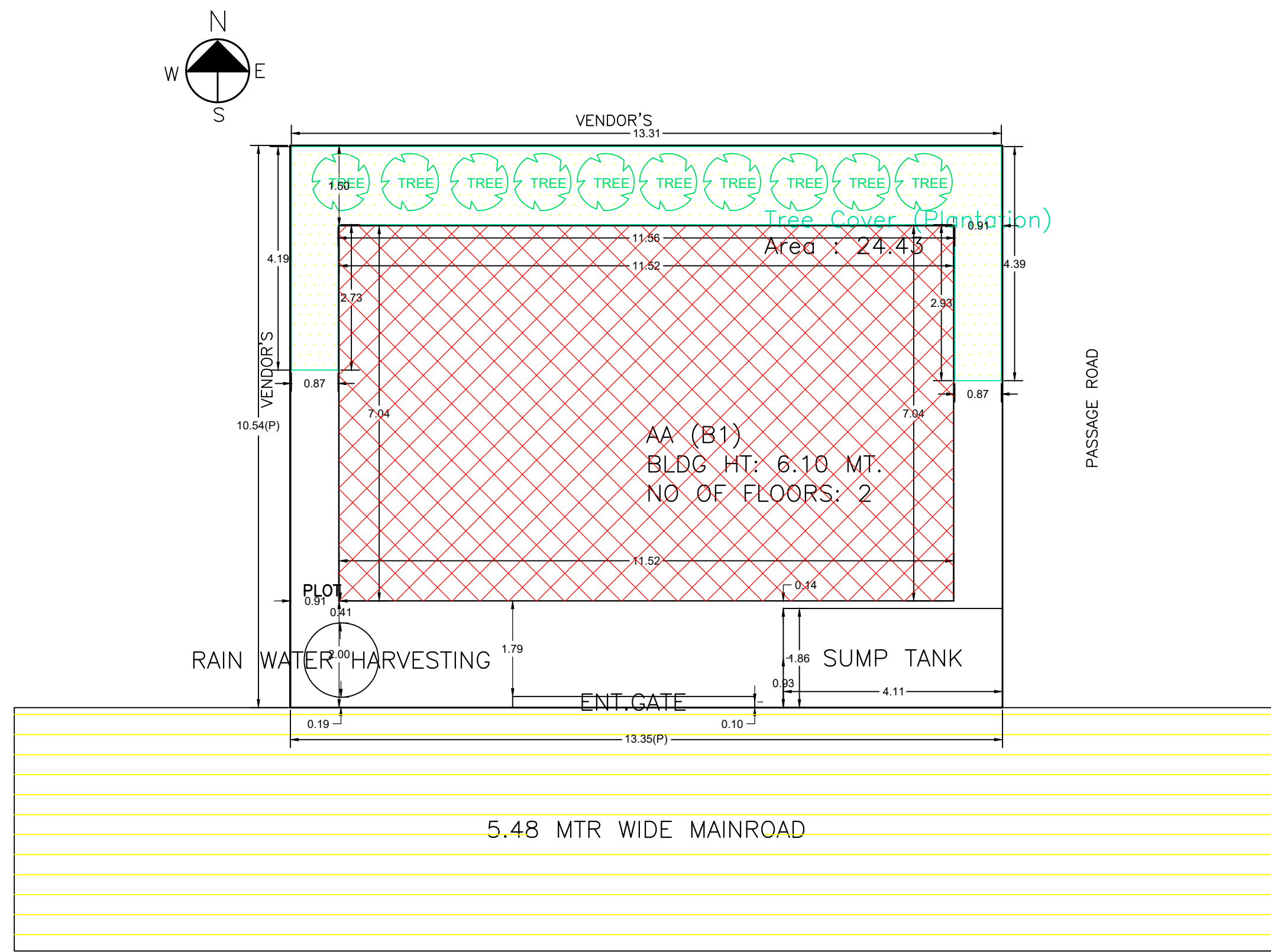

SITE PLAN

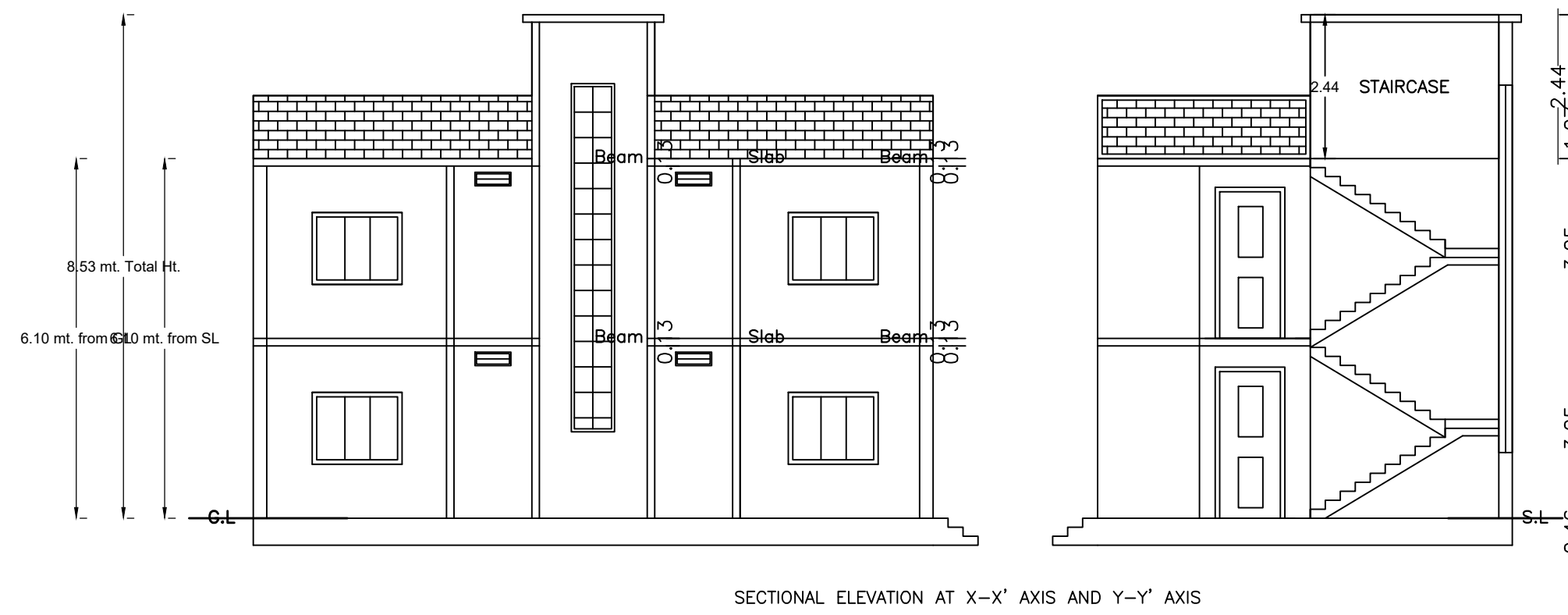

SECTIONAL ELEVATION AT X-X' AXIS AND Y-Y' AXIS



FRONT ELEVATION

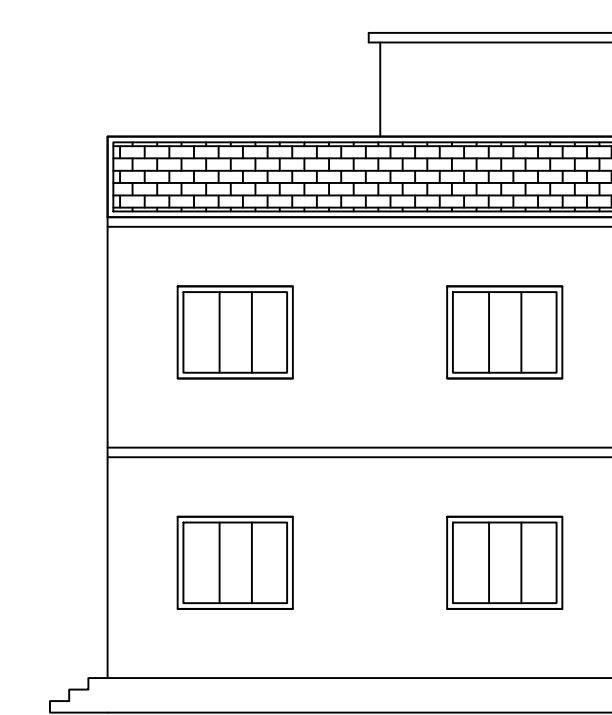

LEFT SIDE ELEVATION

SCHEDULE OF DOOR:

BUILDING NAME	NAME	LENGTH	HEIGHT	NOS
AA (B1)	D	1.03	2.10	01
AA (B1)	D	1.04	2.10	01
AA (B1)	D	1.08	2.10	01
AA (B1)	D	1.12	2.10	02
AA (B1)	D	1.15	2.10	01
AA (B1)	D	1.19	2.10	02
AA (B1)	D	1.20	2.10	02
AA (B1)	D	2.03	2.10	01

SCHEDULE OF WINDOW/VENTILATION:

BUILDING NAME	NAME	LENGTH	HEIGHT	NOS
AA (B1)	W	0.90	1.20	01
AA (B1)	W	0.99	1.20	01
AA (B1)	W	1.05	1.20	01
AA (B1)	W	1.20	1.20	01
AA (B1)	W	1.25	1.20	01
AA (B1)	W	1.35	1.20	01
AA (B1)	W	2.11	1.20	01
AA (B1)	W	2.26	1.20	01
AA (B1)	W	2.27	1.20	01
AA (B1)	W	2.34	1.20	01
AA (B1)	W	2.39	1.20	01
AA (B1)	W	2.49	1.20	01
AA (B1)	W	2.52	1.20	01
AA (B1)	W	2.55	1.20	01
AA (B1)	W	2.56	1.20	01
AA (B1)	W	2.62	1.20	01
AA (B1)	W	2.64	1.20	01
AA (B1)	W	2.67	1.20	01
AA (B1)	W	2.82	1.20	01
AA (B1)	W	3.50	1.20	01
AA (B1)	W	4.09	1.20	01

Building :AA (B1)

Floor Name	Total Built Up Area (Sq.mt.)	Deductions (Area in Sq.mt.)		Proposed FAR Area (Sq.mt.)	Total FAR Area (Sq.mt.)	Total Consumed Additional FAR Area (Sq.mt.)	Trnmt (No.)
		Accessory Use	Resi.				
Ground Floor	81.06	23.05	58.01	58.01	58.01	58.01	01
First Floor	81.06	0.00	81.06	81.06	81.06	81.06	00
Terrace Floor	0.00	0.00	0.00	0.00	0.00	0.00	00
Total :	162.12	23.05	139.07	139.07	139.07	139.07	01

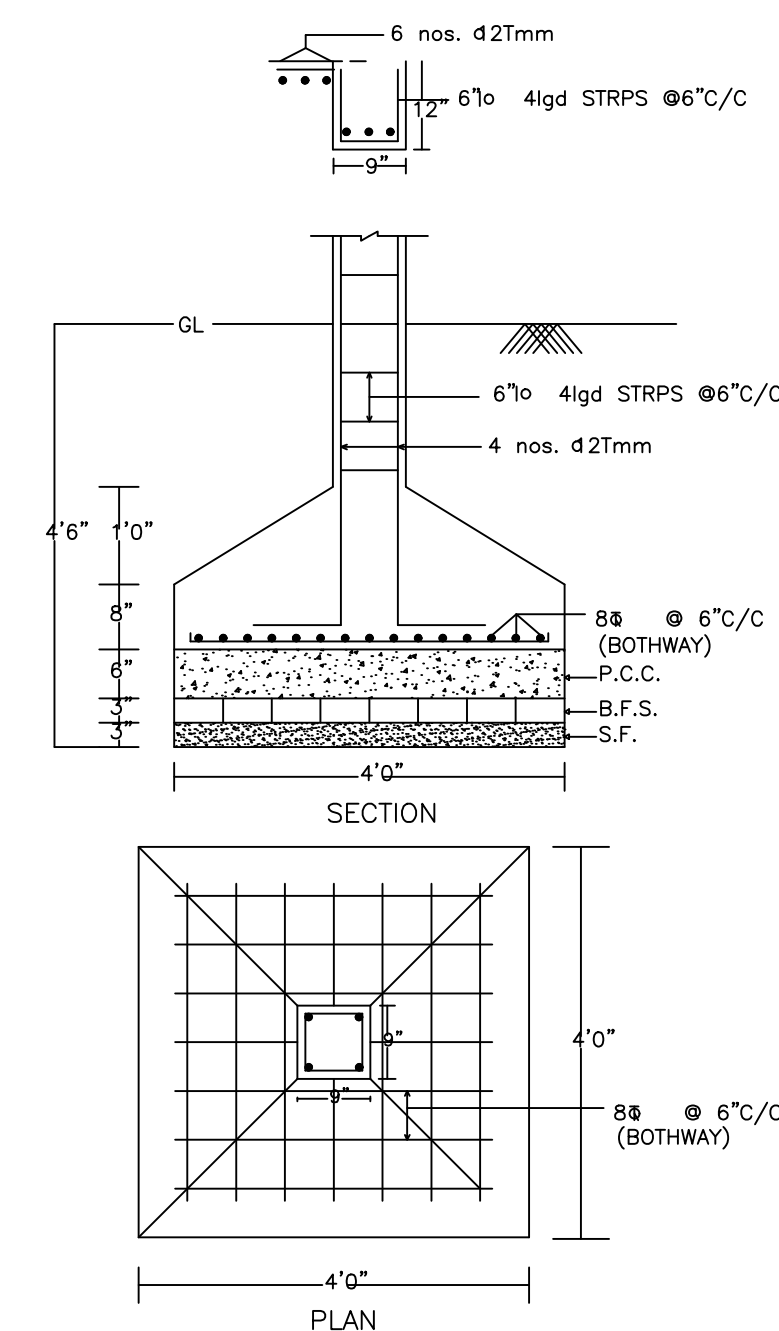

DETAIL OF COLUMNS

SCALE:- 1" = 2' - 0"

UnitBUA Table for Building :AA (B1)

FLOOR	Name	UnitBUA Type	UnitBUA Area	Carpet Area	No. of Rooms	No. of Tenement
GROUND FLOOR	SPLIT 1	FLAT	139.07	138.89	5	1
FIRST FLOOR	SPLIT 1	FLAT	0.00	0.00	7	0
Total:	-	-	139.07	138.89	12	1

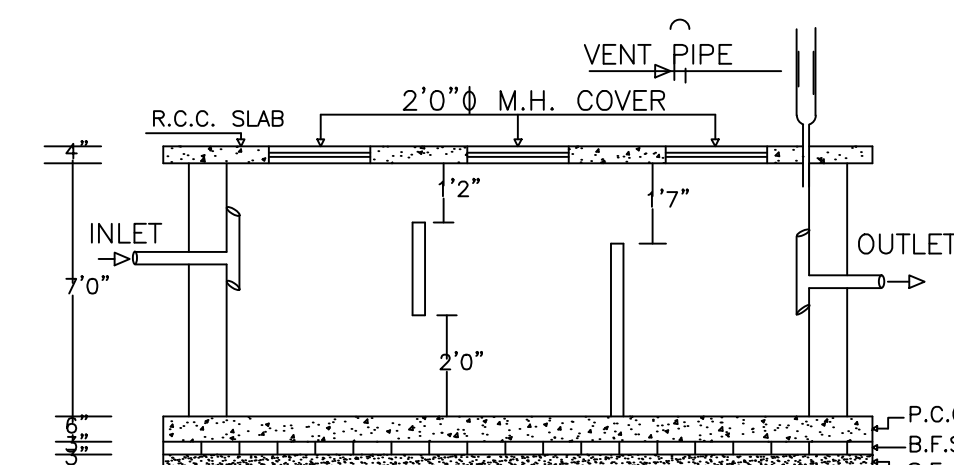
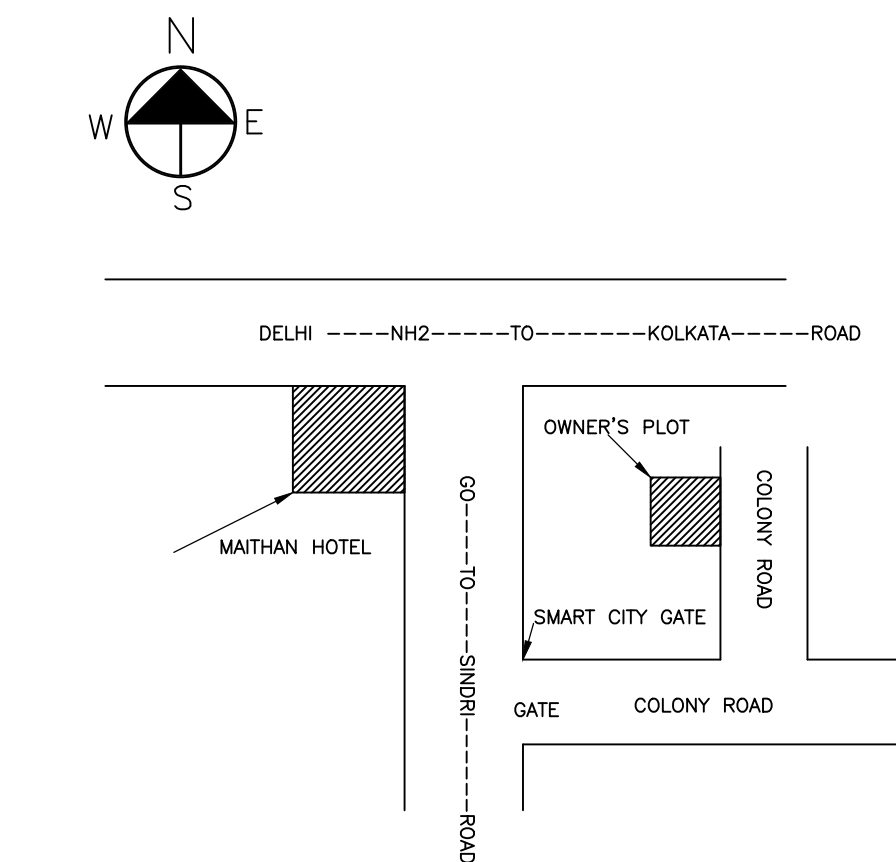

PLAN OF SEPTIC TANK

SCALE:- 1" = 4' - 0"

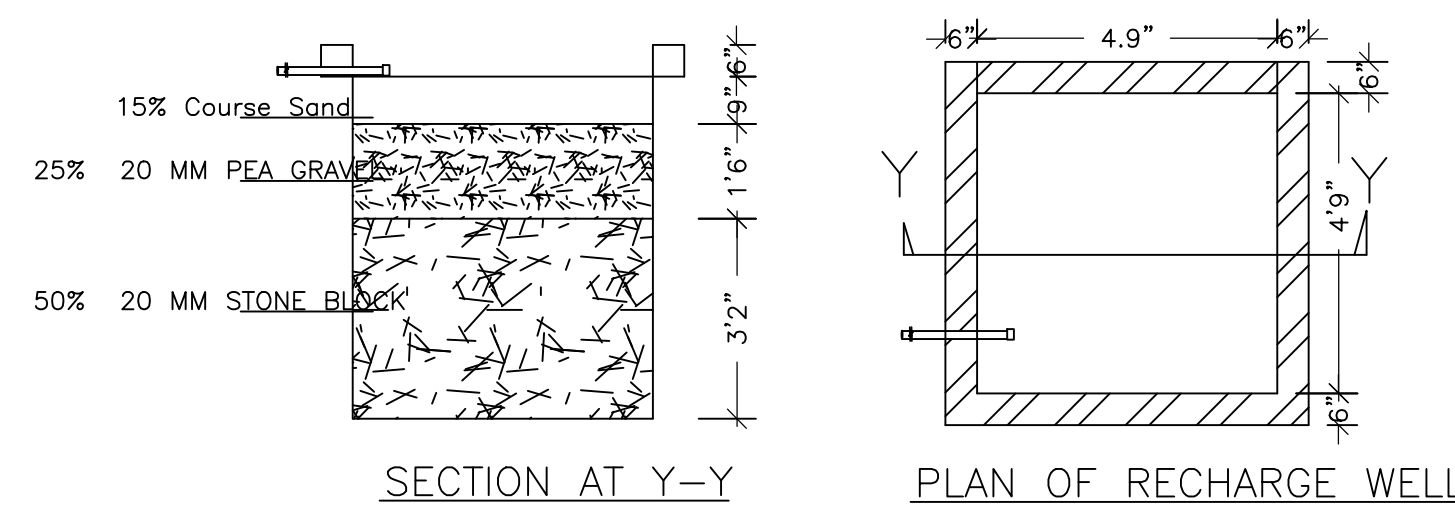

SECTION AT Y-Y

PLAN OF RECHARGE WELL

WATER HARVESTING

Scale 1" = 4' 0"

Proposal Basic Information	
Proposal File No.	MADA/BP/0179/2024
Owner Name	SMT SUSHMA SHARMA
Khata No	NEW- 357, OLD 33
Plot No	NEW- 510,511, OLD 555
Village Name	Merah
Use	Residential
SubUse	Bungalow/ Dwelling / Non Apartment

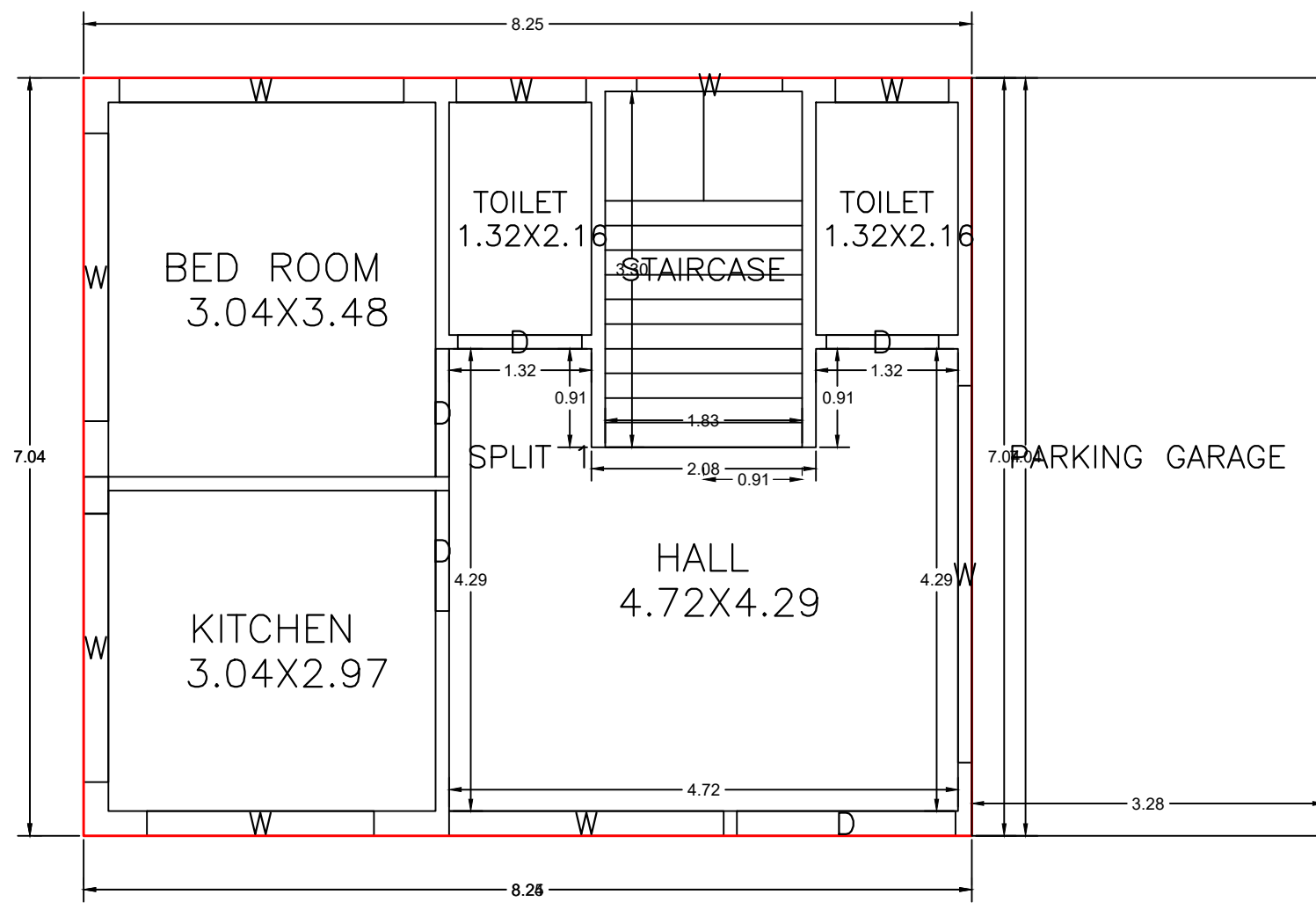

GROUND FLOOR PLAN
(Proposed)
(SCALE 1:100)

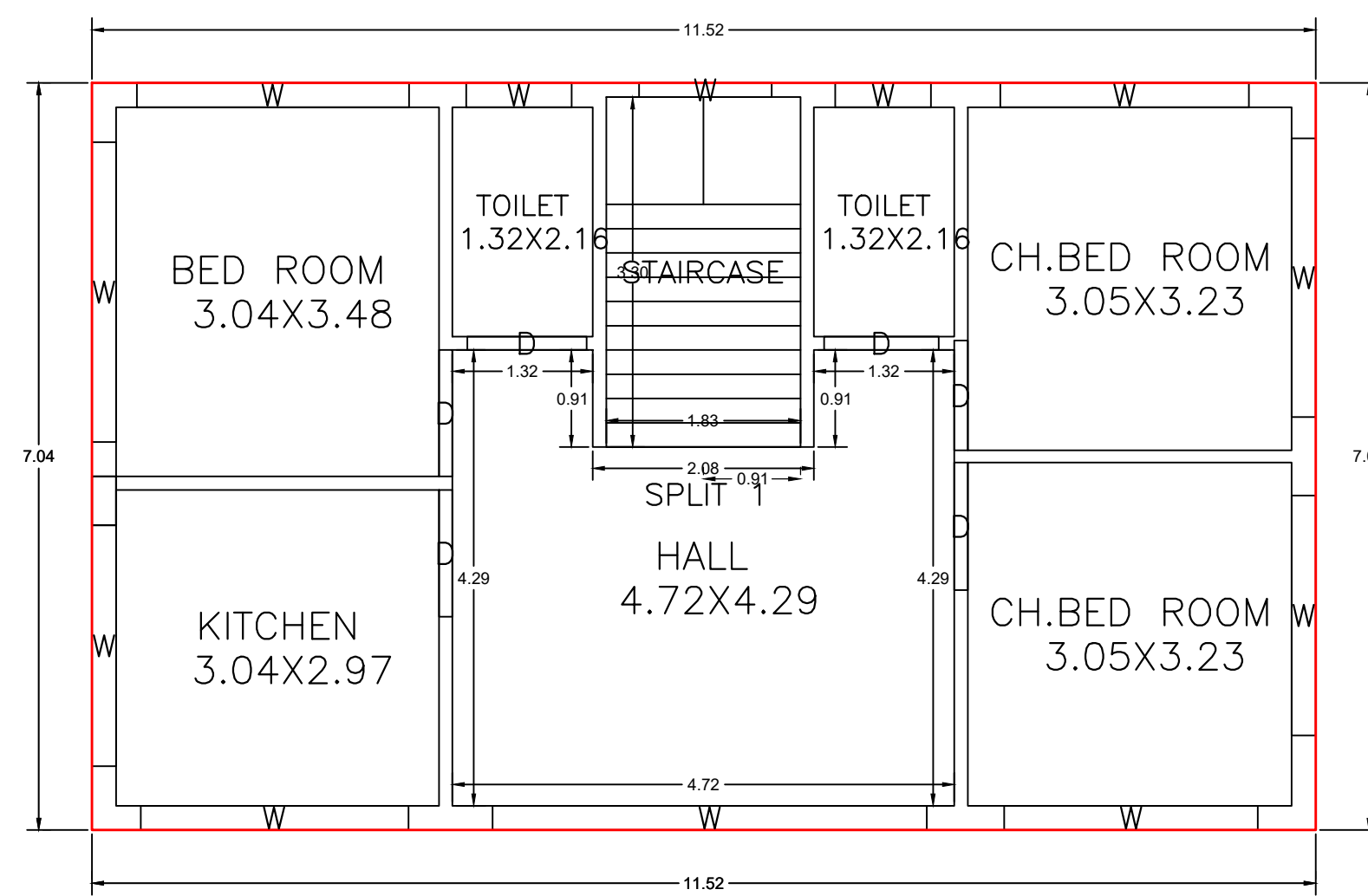

FIRST FLOOR PLAN
(Proposed)
(SCALE 1:100)

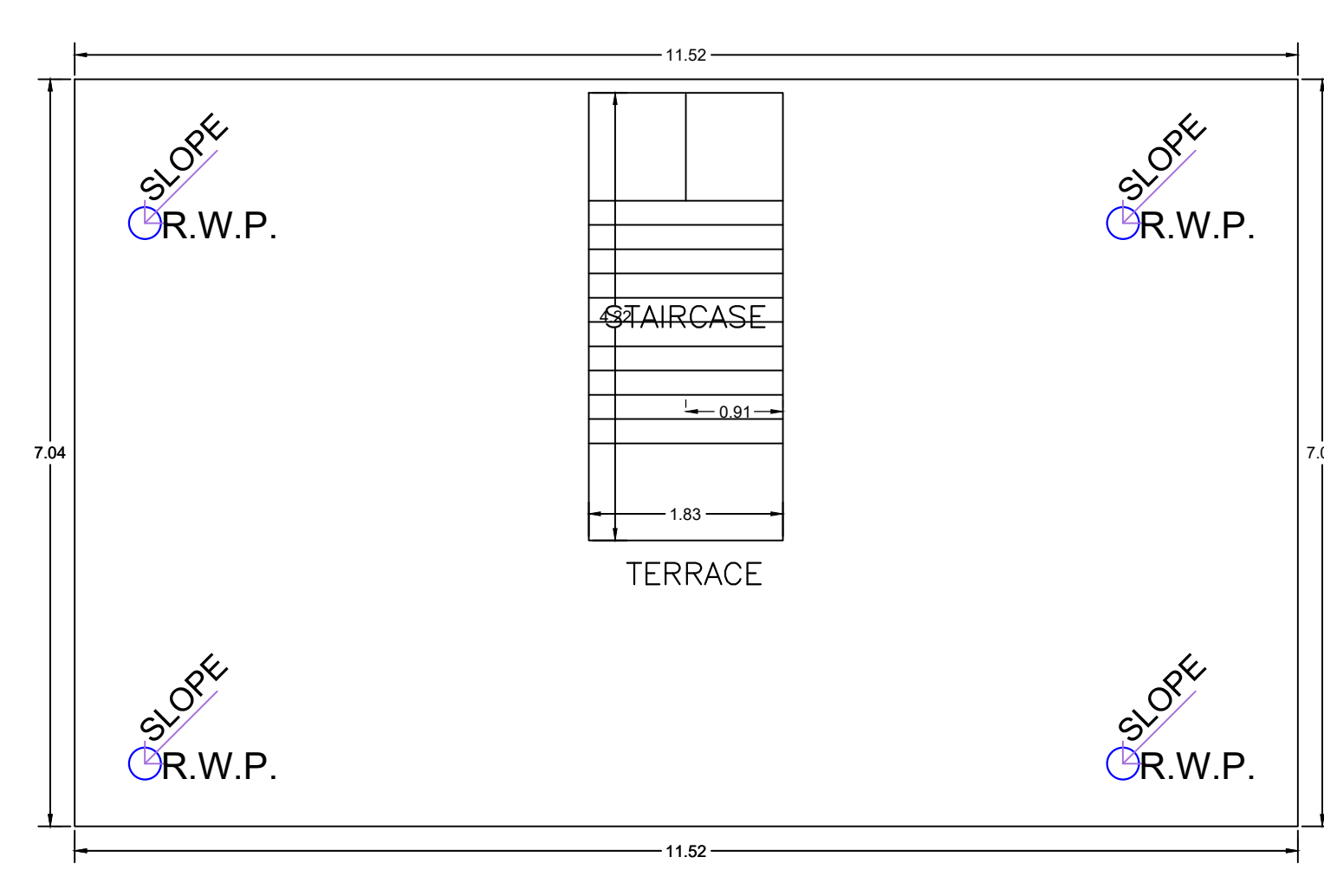

TERRACE FLOOR PLAN
(SCALE 1:100)

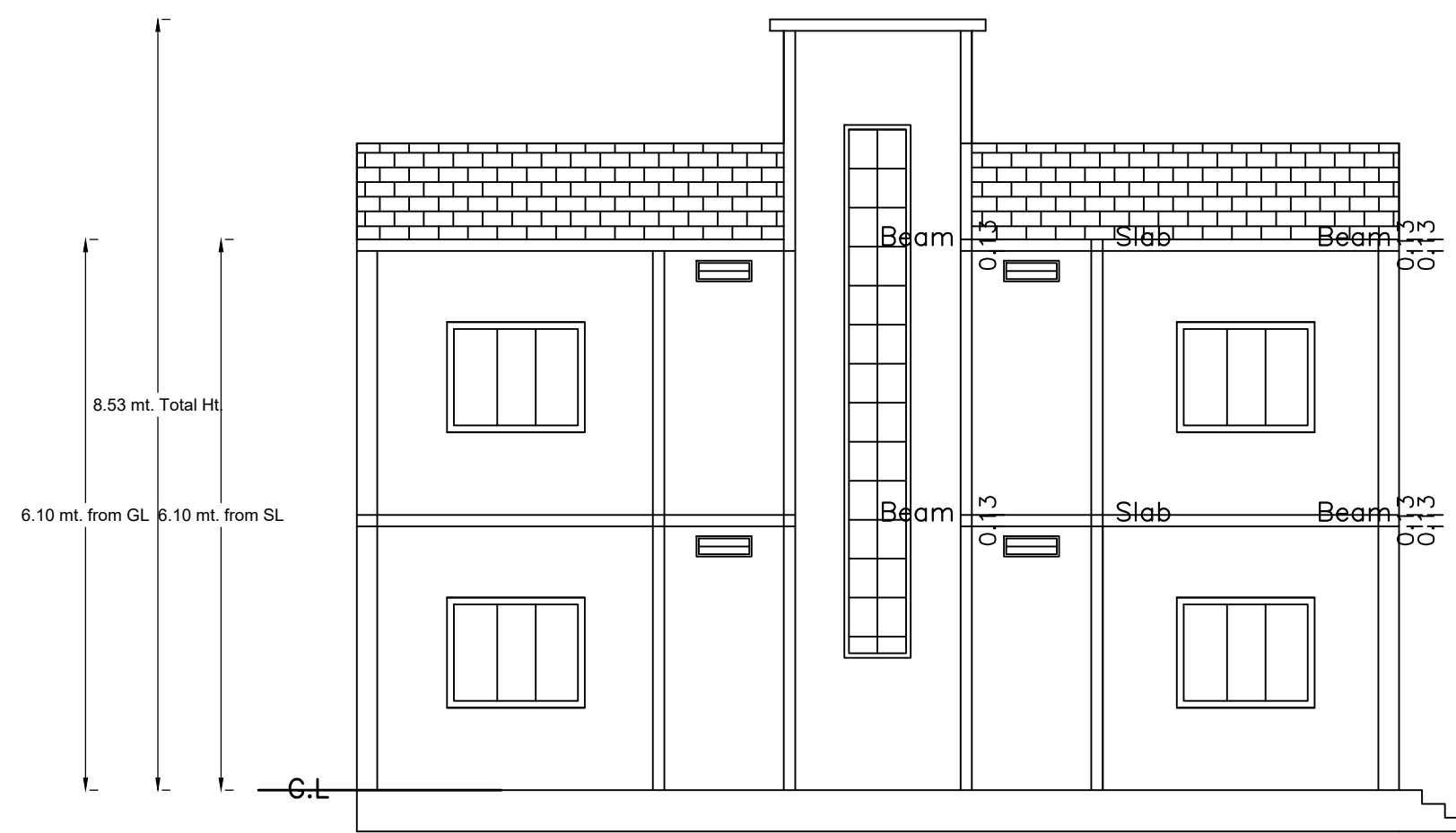

SECTIONAL ELEVATION AT X-X' AXIS AND Y-Y' AXIS

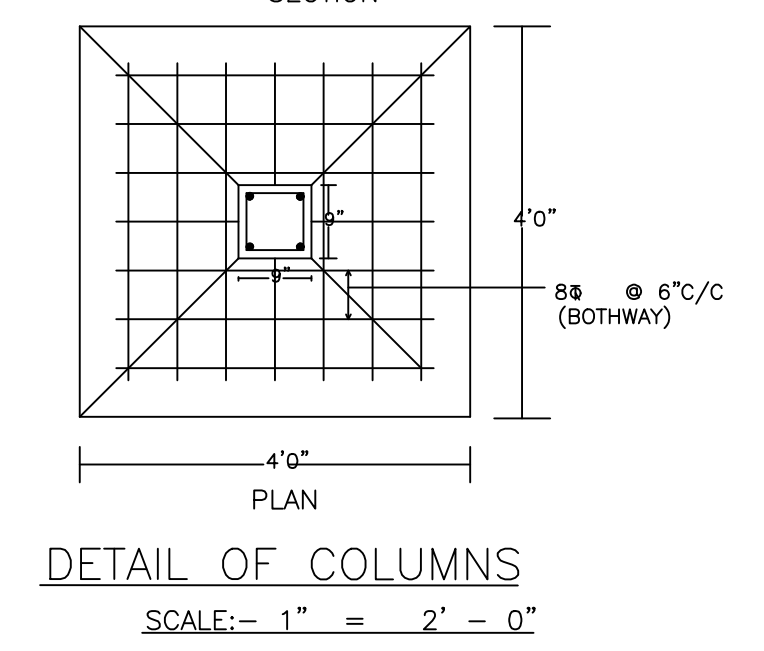
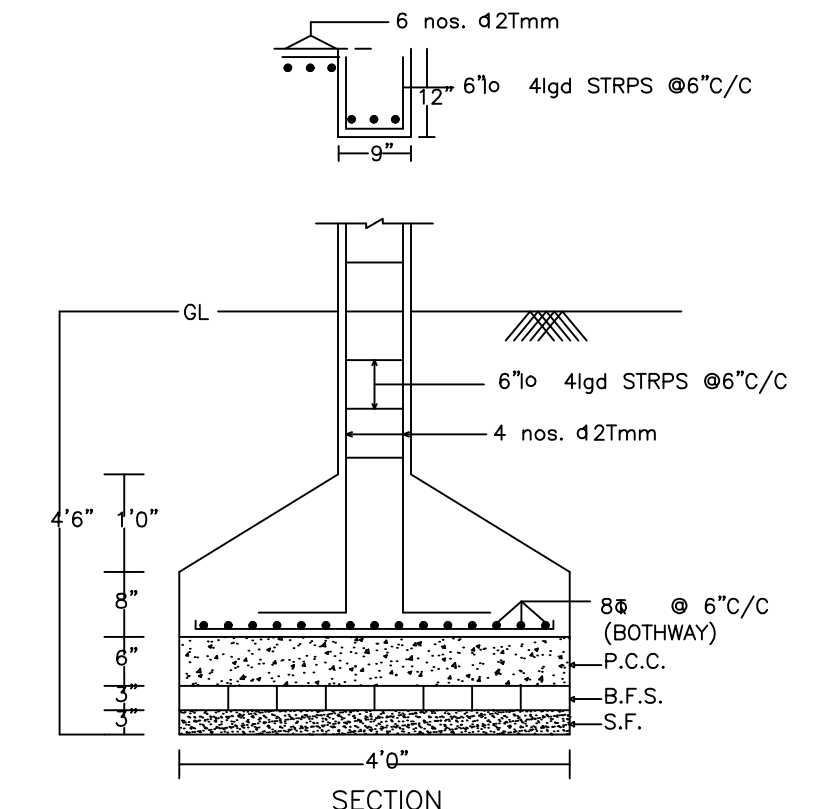
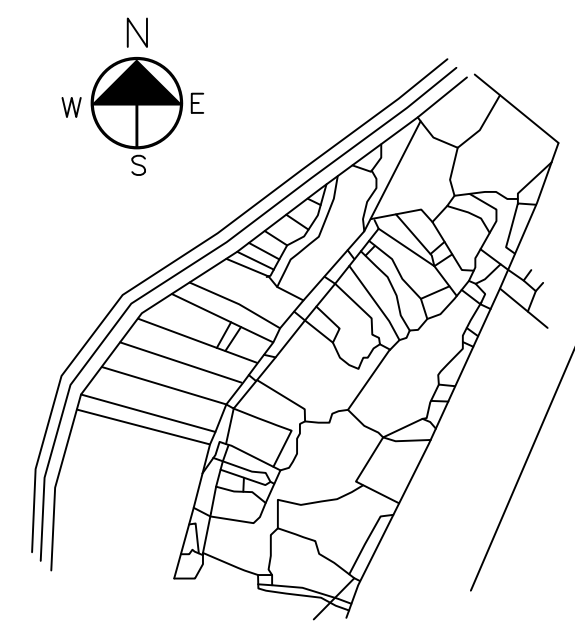
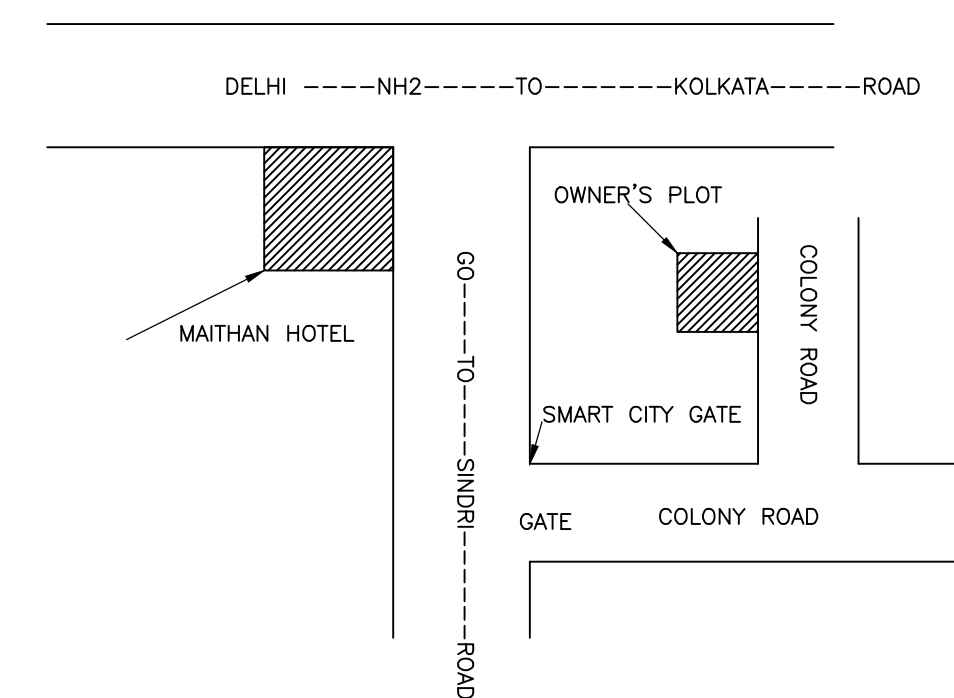
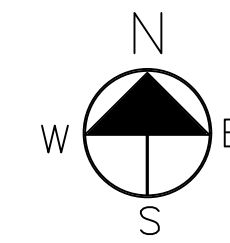
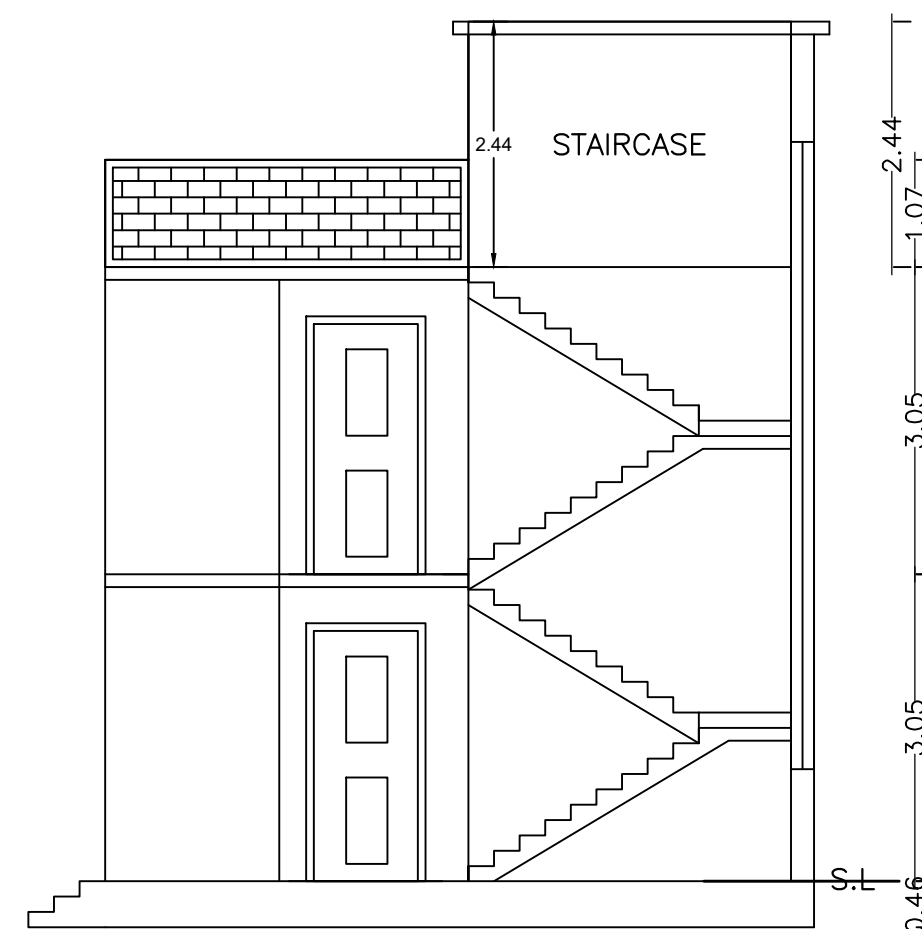

FRONT ELEVATION

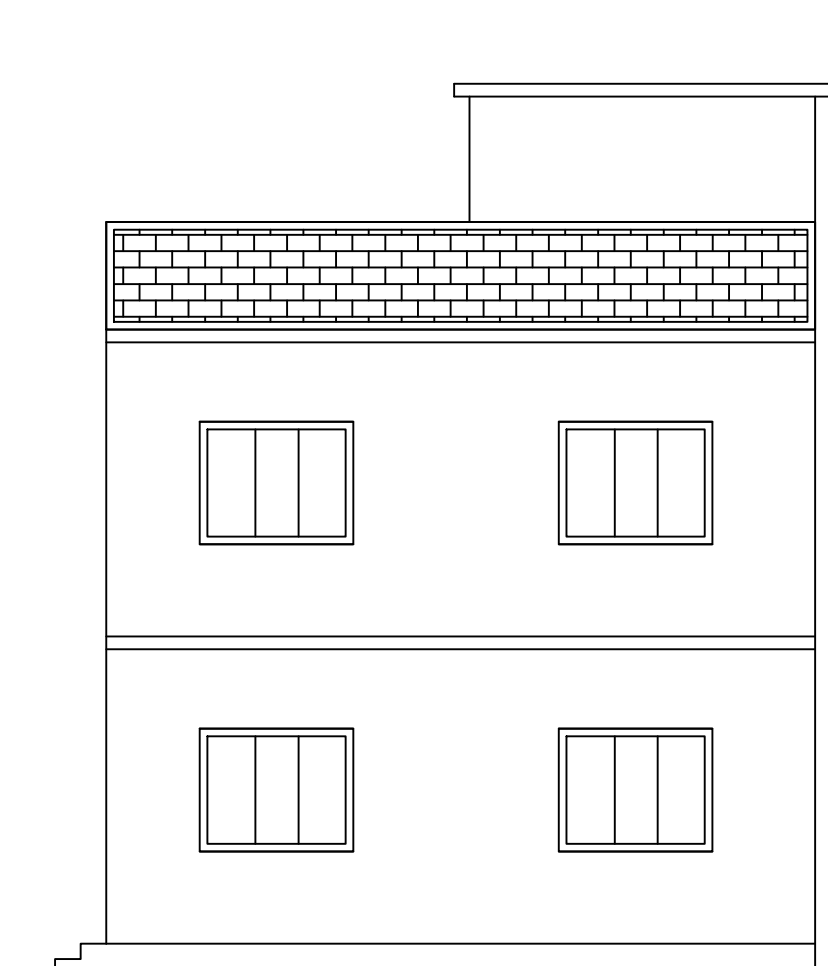

LEFT SIDE ELEVATION

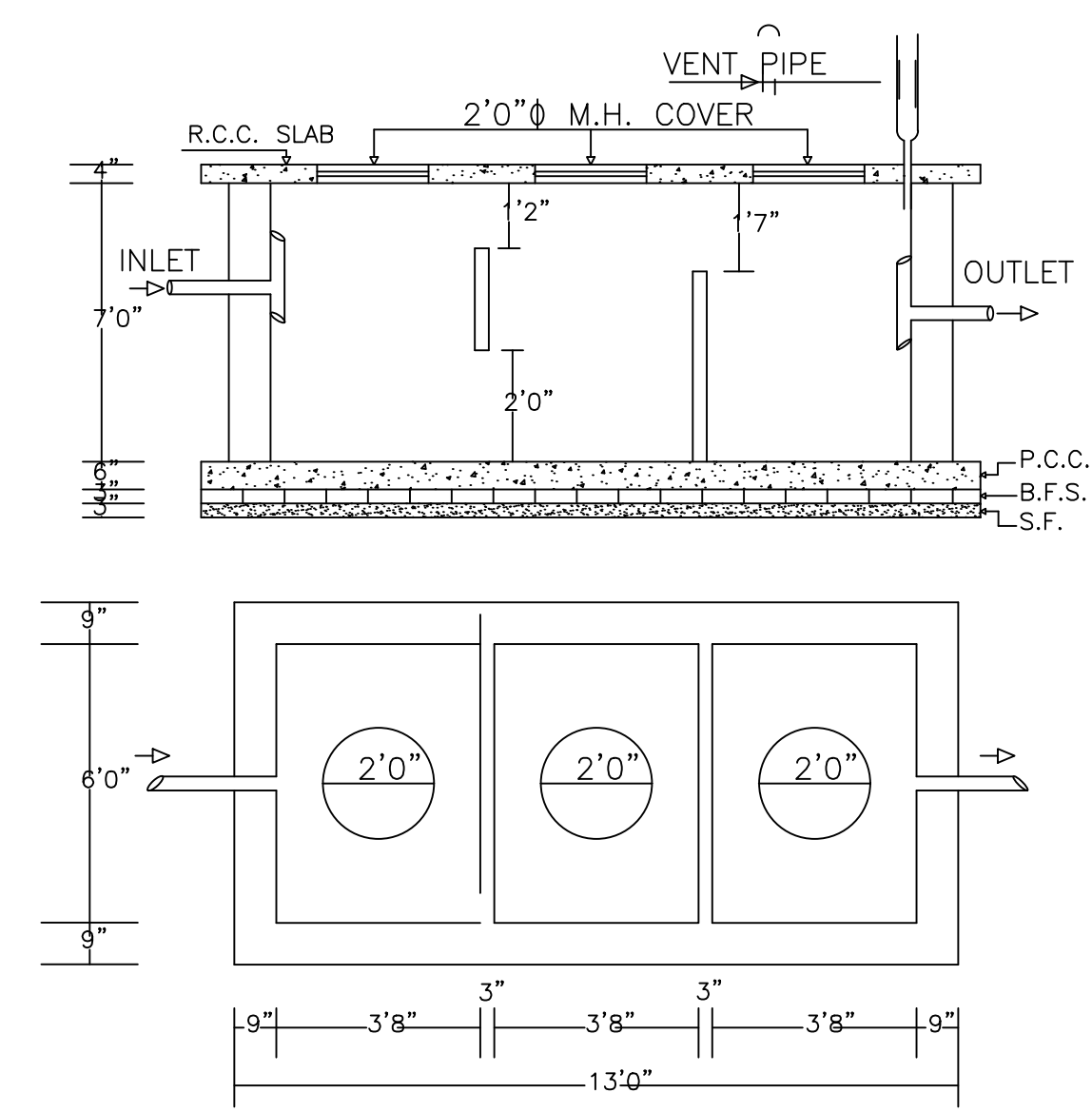

PLAN OF SEPTIC TANK
SCALE:- 1" = 4' - 0"

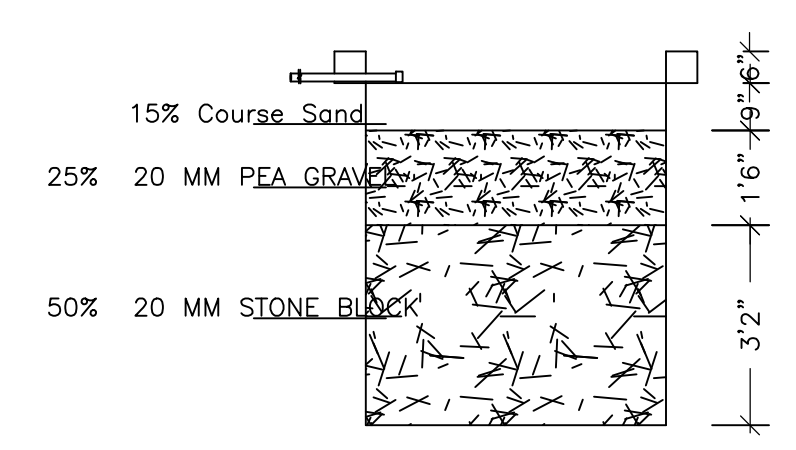

SECTION AT Y-Y

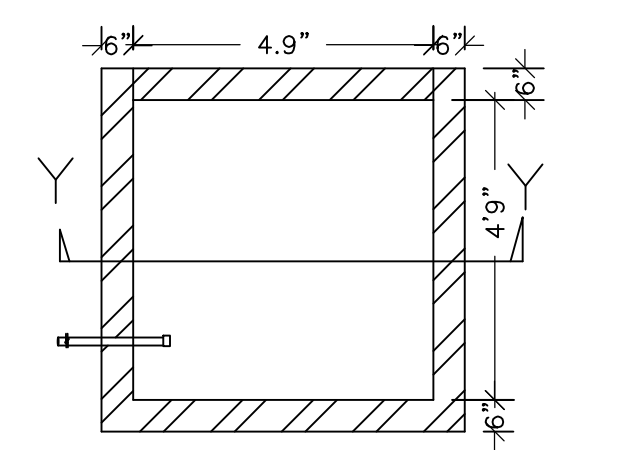

PLAN OF RECHARGE WELL

WATER HARVESTING
Scale 1" = 4' 0"

LTP NAME AND SIGNATURE	STRUCTURAL ENG'S NAME AND SIGNATURE	BUILDER NAME AND SIGNATURE	DIGITAL SIGNATURE
RAJEEV RANJAN SINGH MADA/ENG/0004/2019			