

Proposal Basic Information

Proposal File No.	MADA/BP/0219/2024
Owner Name	SRI BIKRAM KUMAR TIWARY
Khata No	11 (OLD), 92 (NEW)
Plot No	729 (OLD), 513 (NEW)
Village Name	Amaghata
Use	Residential
SubUse	Bungalow/ Dwelling / Non Apartment

AREA STATEMENT MINERAL AREA DEVELOPMENT AUTHORITY	VERSION NO.: 1.0.70 VERSION DATE: 16/10/2020
PROJECT DETAIL:	
Region: JHARKHAND URBAN LOCAL BODIES	Plot Use: Residential
District: DHANBAD	Plot SubUse: Bungalow/ Dwelling / Non Apartment
Authority: MINERAL AREA DEVELOPMENT AUTHORITY	PlotNearbyReligiousStructure: NA
Inward No: MADA/BP/0219/2024	Plot/SubPlot No: 729 (OLD), 513 (NEW)
Application Type: General Proposal	North: Plot No. - LOT NO-283
Project Type: Building Permission	South: Plot No. - PLOT NO-281
Nature of Development: New	East: Plot No. - BOUDARY WALL
Location of Development Area: Old Area	West: Road Width - 9.14
AREA DETAILS:	SQ.MT.
AREA OF PLOT (Minimum)	(A) 104.34
NET AREA OF PLOT(Gross Plot Area - Deduction from Gross Plot area)	(A-Deductions) 104.34
Deduction for Balance Plot Area(from Gross Plot Area)	
Common Plot	10.48
Total	10.48
BALANCE AREA OF PLOT(Net Plot Area - Recreational/Amenity space)	(A-Deductions) 93.86
PLOT AREA FOR COVERAGE(Net Plot Area)	(A-Deductions) 104.34
Plot Area for FAR (Net Plot Area + RoadWidening Area)	(A-Deductions) 104.34
COVERAGE CHECK	
Permissible Coverage area (70.00 %)	73.04
Proposed Coverage Area (54.84 %)	57.22
Total Prop. Coverage Area (54.84 %)	57.22
Balance coverage area (15.16 %)	15.82
FAR CHECK	
Perm. FAR Area (2.500)	260.85
Total Perm. FAR area	260.85
Residential FAR	105.53
Proposed FAR Area	105.53
Total Proposed FAR Area	105.53
Consumed FAR (Factor)	1.01
Balance FAR Area	155.32
BUILT UP AREA CHECK	
Total Proposed BuiltUp Area	105.53
ARCHITECT (Regd)	ANIL KUMAR CHAUDHARY
ENGINEER (Regd)	
SUPERVISOR (Regd)	
OWNER (Regd)	SRI BIKRAM KUMAR TIWARY
DEVELOPMENT AUTHORITY	LOCAL BODY

COLOR INDEX	
PLOT BOUNDARY	Black
ABUTTING ROAD	Red
PROPOSED CONSTRUCTION	Green
COMMON PLOT	Yellow
ROAD WIDENING AREA	Blue
EXISTING (To be retained)	Light Blue
EXISTING (To be demolished)	Orange

Floor Name	Building Name		Total	
	Proposed Built Up Area (Sq.mt.)	Proposed FAR Area (Sq.mt.)	Total Proposed Built Up Area (Sq.mt.)	Total FAR Area (Sq.mt.)
Ground Floor	57.22	57.22	57.22	57.22
First Floor	48.31	48.31	48.31	48.31
Terrace Floor	0.00	0.00	0.00	0.00
Total :	105.53	105.53	105.53	105.53

Building Name	Building Use	Building SubUse	Building Structure
RESI (TIWARY)	Residential	Bungalow/ Dwelling / Non Apartment	Non-Highrise

FAR & Tenement Details (Table 4c-1)							
Building	No. of Same Bldg	Gross Built Up Area (Sq.mt.)	Deductions From Gross BUA/Area in Sq.mt.	Total Built Up Area (Sq.mt.)	Proposed FAR Area (Sq.mt.)	Total Consumed Additional FAR Area (Sq.mt.)	Trmt (No.)
RESI (TIWARY)	1	107.14	1.61	105.53	105.53	105.53	01
Grand Total :	1	107.14	1.61	105.53	105.53	105.53	01

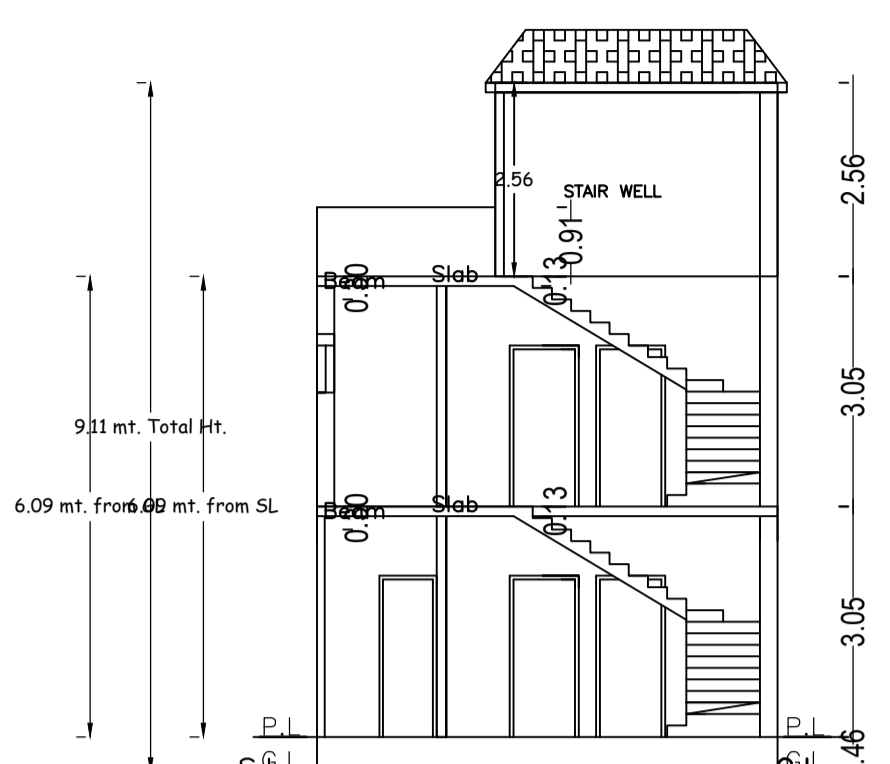
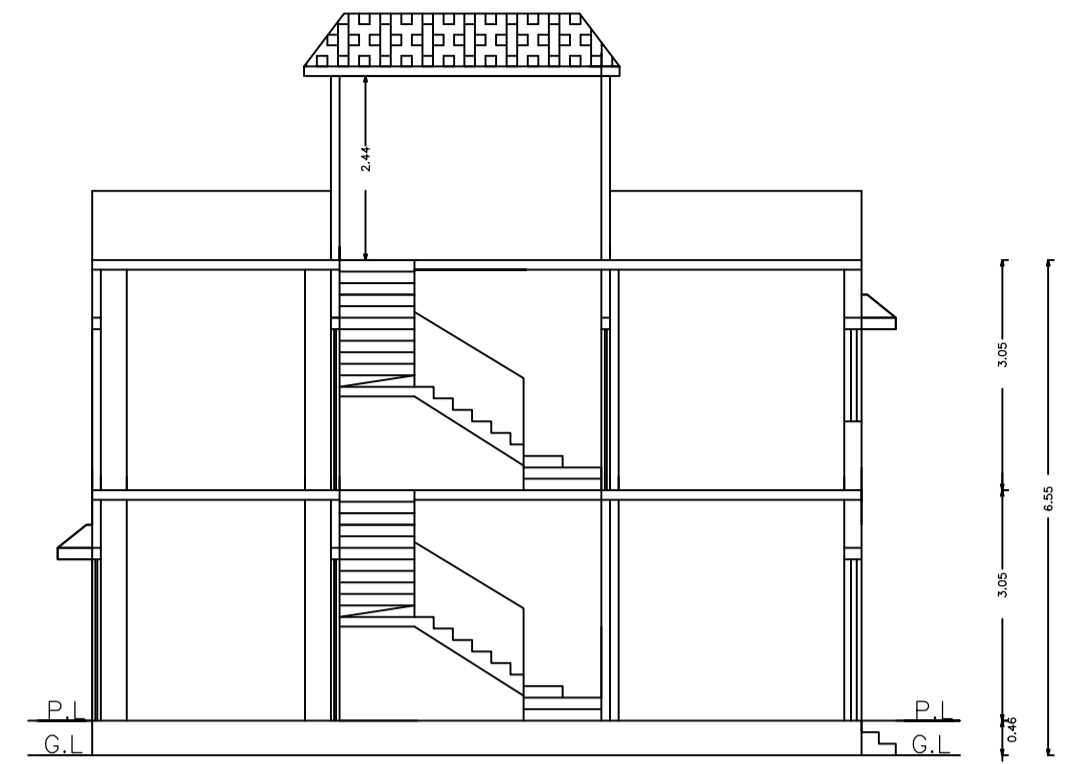

SECTION AT X-X

SECTION AT Y-Y

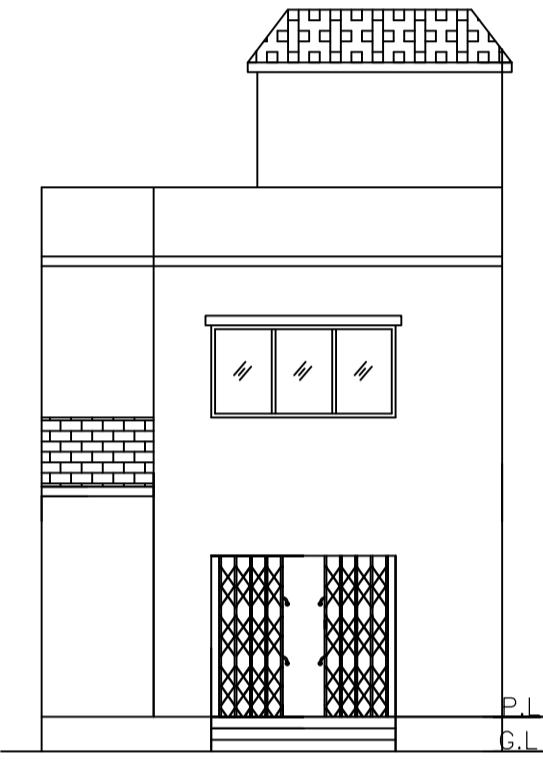

FRONT ELEVATION

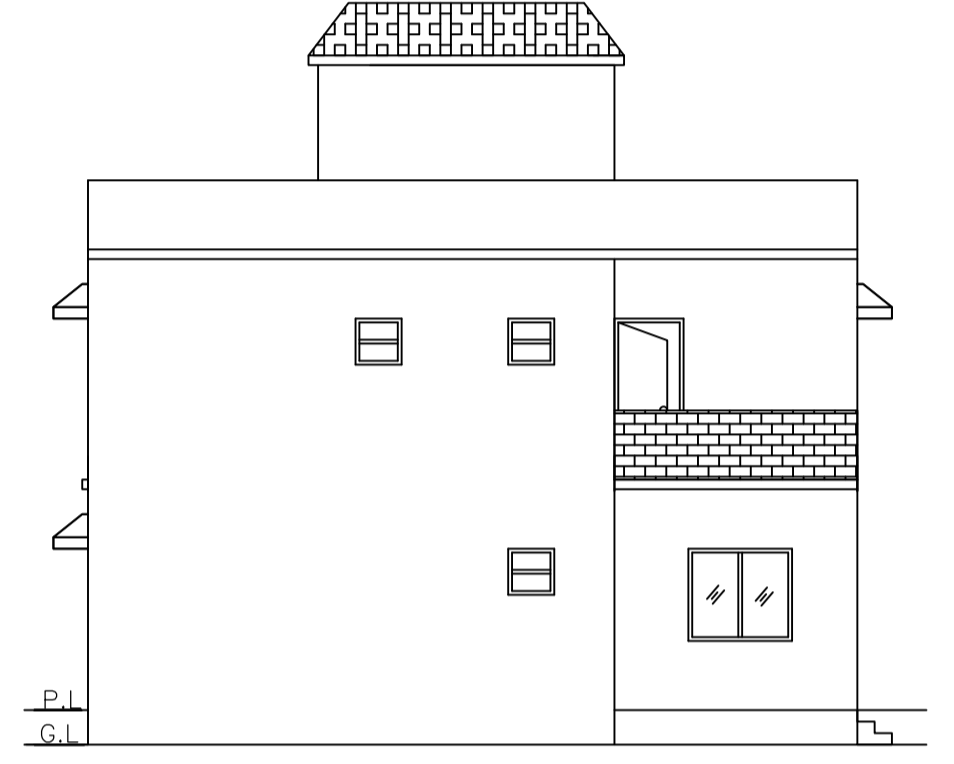

RIGHT SIDE ELEVATION

UnitBUA Table for Building :RESI (TIWARY)

FLOOR	Name	UnitBUA Type	UnitBUA Area	Carpet Area	No. of Rooms	No. of Tenement
GROUND FLOOR	SPLIT 1	FLAT	105.53	105.07	5	1
FIRST FLOOR	SPLIT 1	FLAT	0.00	0.00	4	0
Total:	-	-	105.53	105.07	9	1

SCHEDULE OF DOOR:

BUILDING NAME	NAME	LENGTH	HEIGHT	NOS
RESI (TIWARY)	D	0.76	2.10	02
RESI (TIWARY)	D	0.84	2.10	01
RESI (TIWARY)	D	0.86	2.10	01
RESI (TIWARY)	D	0.91	2.10	02
RESI (TIWARY)	D	0.93	2.10	01
RESI (TIWARY)	D	0.94	2.10	01
RESI (TIWARY)	D	0.99	2.10	03
RESI (TIWARY)	D	1.22	2.10	01
RESI (TIWARY)	D	2.44	2.10	01

SCHEDULE OF WINDOW/VENTILATION:

BUILDING NAME	NAME	LENGTH	HEIGHT	NOS
RESI (TIWARY)	W	0.61	1.20	03
RESI (TIWARY)	W	0.80	1.20	01
RESI (TIWARY)	W	1.37	1.20	02
RESI (TIWARY)	W	1.79	1.20	01
RESI (TIWARY)	W	2.44	1.20	01

Building :RESI (TIWARY)

Floor Name	Gross Builtup Area	Deductions From Gross BUA/Area in Sq.mt.	Total Built Up Area (Sq.mt.)	Proposed FAR Area (Sq.mt.)	Total FAR Area (Sq.mt.)	Total Consumed Additional FAR Area (Sq.mt.)	Trmt (No.)
Ground Floor	57.22	0.00	57.22	57.22	57.22	57.22	01
First Floor	48.31	1.61	46.70	46.70	46.70	46.70	00
Terrace Floor	0.00	0.00	0.00	0.00	0.00	0.00	00
Total :	107.14	1.61	105.53	105.53	105.53	105.53	01
Total Number of Same Buildings	1						
Total :	107.14	1.61	105.53	105.53	105.53	105.53	01

LTP NAME AND SIGNATURE	STRUCTURAL ENG'S NAME AND SIGNATURE	BUILDER NAME AND SIGNATURE	DIGITAL SIGNATURE
ANIL KUMAR CHAUDHARY MADA/ENG/0005/2019			

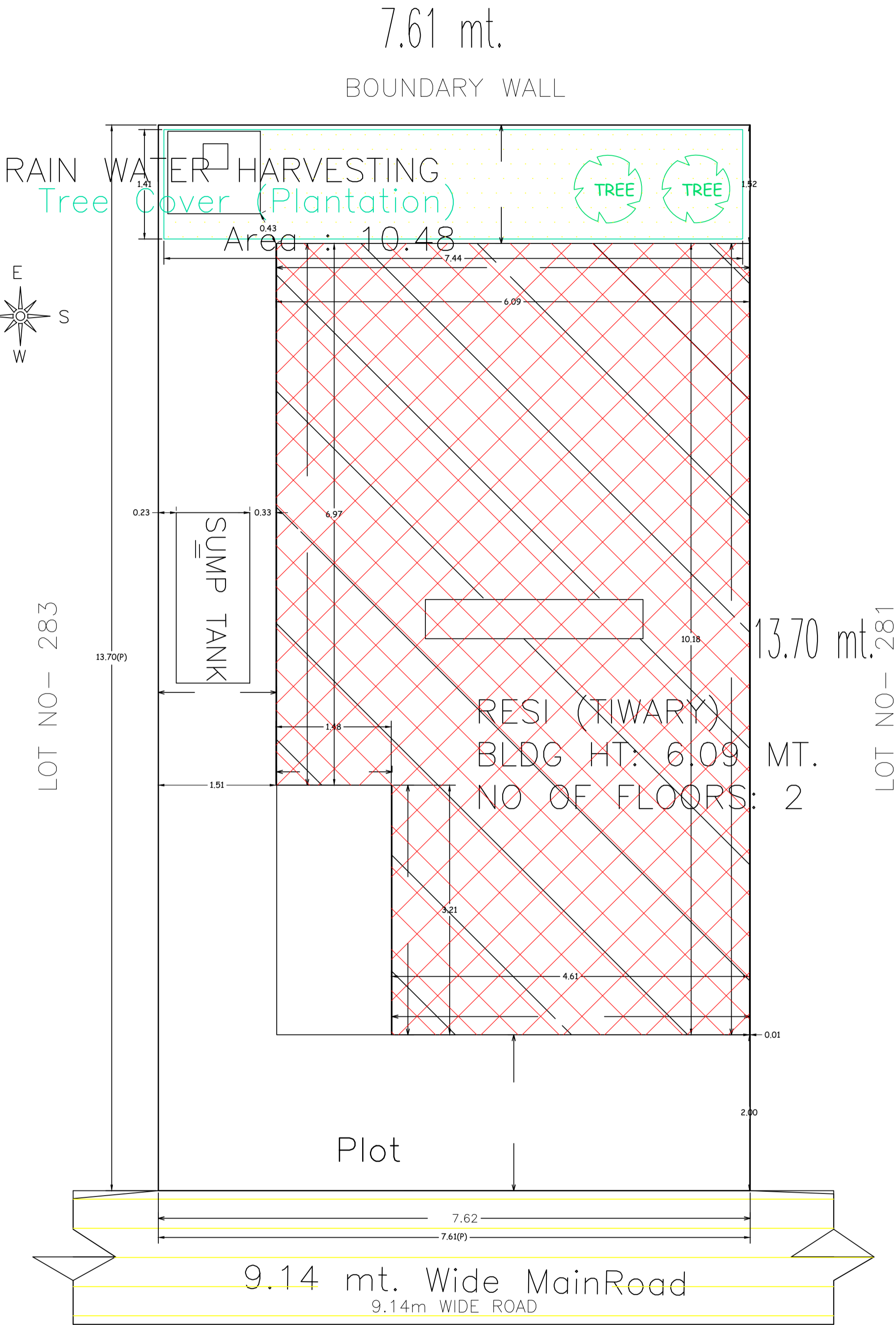

SITE PLAN
SITE PLAN

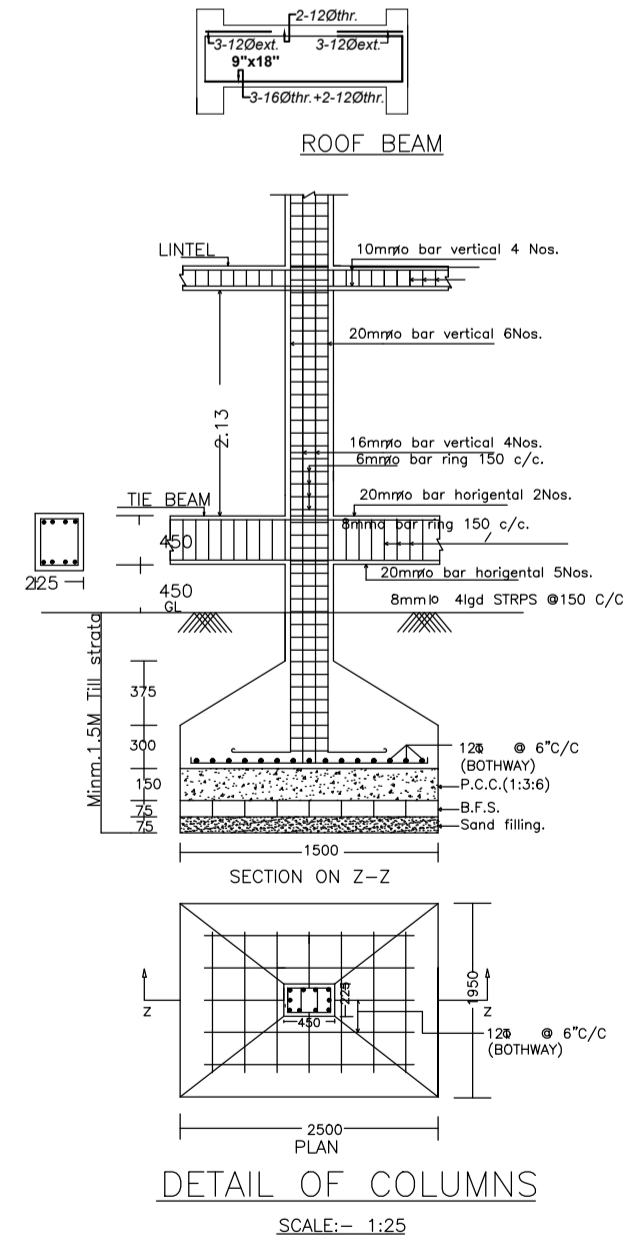

DETAIL OF COLUMNS
SCALE:- 1:25

