

SECTION AT X-X

SECTION AT Y-Y

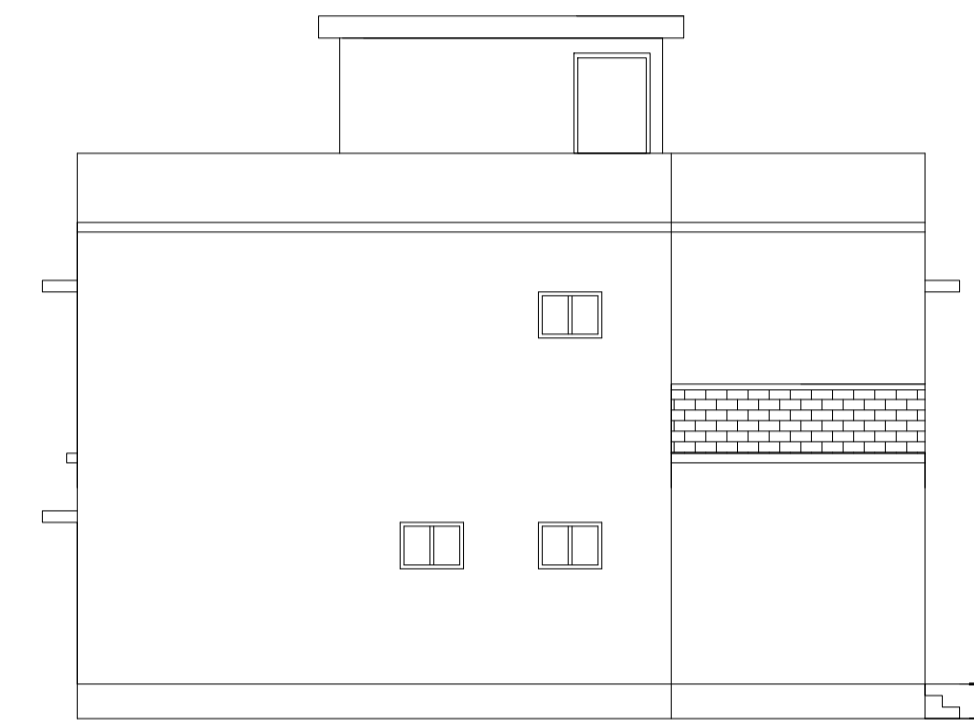
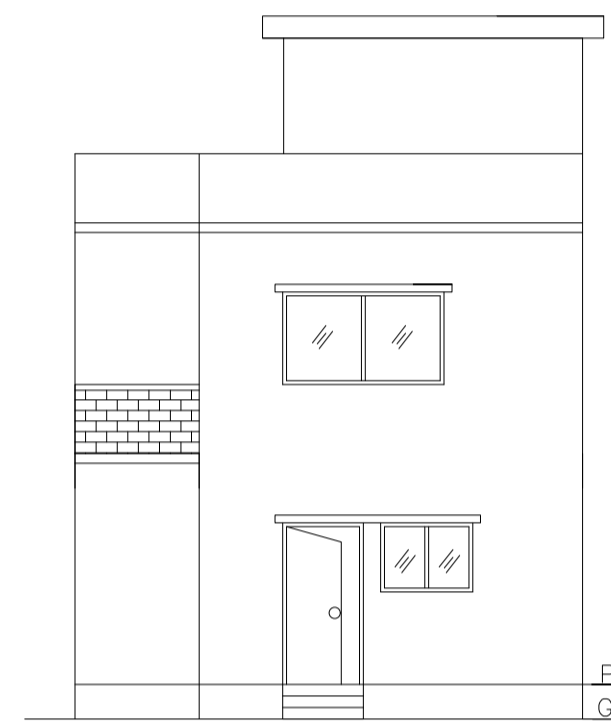

FRONT ELEVATION

LEFT SIDE ELEVATION

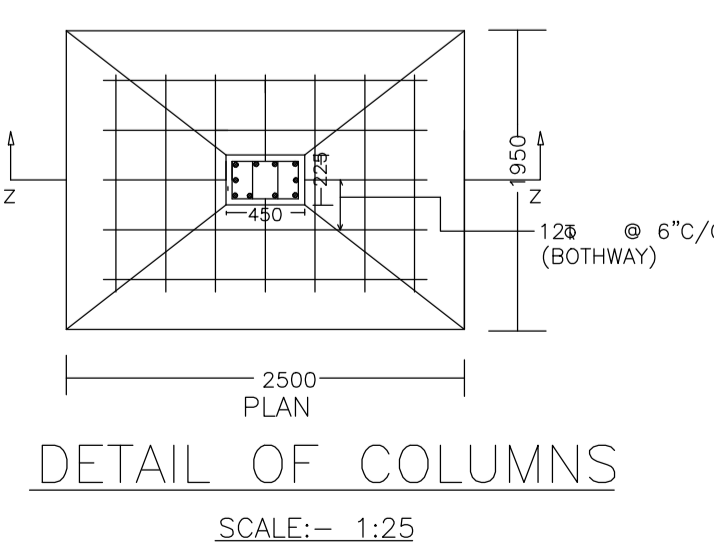
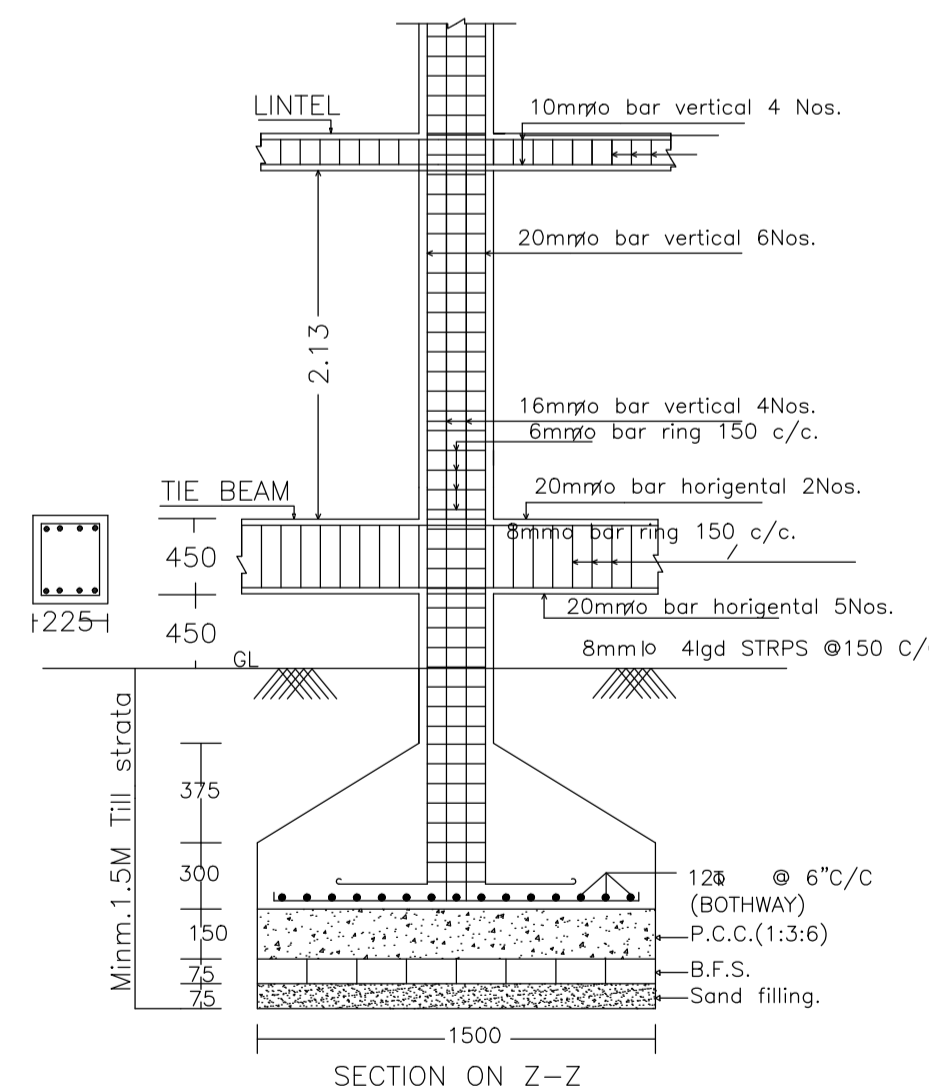
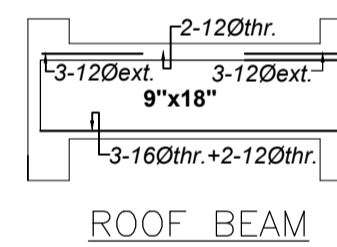

UnitBUA Table for Building :RESI (UDAY)

FLOOR	Name	UnitBUA Type	UnitBUA Area	Carpet Area	No. of Rooms	No. of Tenement
GROUND FLOOR PLAN	SPLIT 1	FLAT	141.11	139.05	6	1
FIRST FLOOR PLAN	SPLIT 1	FLAT	0.00	0.00	7	0
Total:	-	-	141.11	139.05	13	1

SCHEDULE OF DOOR:

BUILDING NAME	NAME	LENGTH	HEIGHT	NOS
RESI (UDAY)	D	0.65	2.10	01
RESI (UDAY)	D	0.73	2.10	03
RESI (UDAY)	D	0.79	2.10	01
RESI (UDAY)	D	0.81	2.10	01
RESI (UDAY)	D	0.82	2.10	01
RESI (UDAY)	D	0.88	2.10	01
RESI (UDAY)	D	0.89	2.10	02
RESI (UDAY)	D	0.92	2.10	01
RESI (UDAY)	D	1.07	2.10	01

SCHEDULE OF WINDOW/VENTILATION:

BUILDING NAME	NAME	LENGTH	HEIGHT	NOS
RESI (UDAY)	W	0.61	1.20	04
RESI (UDAY)	W	1.07	1.20	01
RESI (UDAY)	W	1.38	1.20	01
RESI (UDAY)	W	1.53	1.20	03
RESI (UDAY)	W	2.14	1.20	01

Building :RESI (UDAY)

Floor Name	Gross Builtup Area	Deductions From Gross BUA(Area in Sq.mt.)	Total Built Up Area (Sq.mt.)	Proposed FAR Area (Sq.mt.)	Total FAR Area (Sq.mt.)	Total Consumed Additional FAR Area (Sq.mt.)	Tnmt (No.)
Ground Floor	69.78	0.00	69.78	69.78	69.78	69.78	01
First Floor	72.57	1.24	71.33	71.33	71.33	71.33	00
Terrace Floor	0.00	0.00	0.00	0.00	0.00	0.00	00
Total :	142.35	1.24	141.11	141.11	141.11	141.11	01
Total Number of Same Buildings :	1						
Total :	142.35	1.24	141.11	141.11	141.11	141.11	01

FAR & Tenement Details (Table 4c-1)

Building	No. of Same Bldg	Gross Built Up Area (Sq.mt.)	Deductions From Gross BUA(Area in Sq.mt.)	Total Built Up Area (Sq.mt.)	Proposed FAR Area (Sq.mt.)	Total FAR Area (Sq.mt.)	Total Consumed Additional FAR Area (Sq.mt.)	Tnmt (No.)
RESI (UDAY)	1	142.35	1.24	141.11	141.11	141.11	141.11	01
Grand Total :	1	142.35	1.24	141.11	141.11	141.11	141.11	01

Proposal Basic Information

Proposal File No.	MADA/BP/02/17/2024
Owner Name	SRI UDAY KUMAR AGARWAL
Khata No	11 (OLD), 220 (NEW)
Plot No	723/2112(OLD),515 (NEW)
Village Name	Amaghata
Use	Residential
SubUse	Bungalow/ Dwelling / Non Apartment

AREA STATEMENT MINERAL AREA DEVELOPMENT AUTHORITY

VERSION NO.: 1.0.70  
VERSION DATE: 16/10/2020

PROJECT DETAIL:

Region: JHARKHAND URBAN	Plot Use: Residential
District: DHANBAD	Plot SubUse: Bungalow/ Dwelling / Non Apartment
Authority: MINERAL AREA DEVELOPMENT AUTHORITY	PlotNearbyReligiousStructure: NA
Inward No: MADA/BP/02/17/2024	Plot/SubPlot No: 723/2112(OLD),515 (NEW)
Application Type: General Proposal	North: Plot No. - LOT NO-262
Project Type: Building Permission	South: Plot No. - PLOT NO-264
Nature of Development: New	East: Plot No. - PLOT NO-265 & PARK
Location of Development Area: Old Area	West: Road Width - 9.14

AREA DETAILS:

AREA OF PLOT (Minimum)	(A)	SQ.MT.
NET AREA OF PLOT(Gross Plot Area - Deduction from Gross Plot area)	(A-Deductions)	115.71
Deduction for Balance Plot Area(from Gross Plot Area)		
Common Plot		10.07
Total		10.07
BALANCE AREA OF PLOT(Net Plot Area - Recreational/Amenity space)	(A-Deductions)	105.64
PLOT AREA FOR COVERAGE(Net Plot Area)	(A-Deductions)	115.71
Plot Area for FAR (Net Plot Area + Road Widening Area)	(A-Deductions)	115.71

COVERAGE CHECK

Permissible Coverage area ( 70.00 % )	81.00
Proposed Coverage Area ( 60.30 % )	69.78
Total Prop. Coverage Area ( 60.3 % )	69.78
Balance coverage area ( 9.70 % )	11.22

FAR CHECK

Perm. FAR Area ( 2.500 )	289.27
Total Perm. FAR area	289.27
Residential FAR	141.11
Proposed FAR Area	141.11
Total Proposed FAR Area	141.11
Consumed FAR (Factor)	1.22
Balance FAR Area	148.16

BUILT UP AREA CHECK

Total Proposed BuiltUp Area	141.11
-----------------------------	--------

ARCHITECT (Regd) ANIL KUMAR CHAUDHARY  
ENGINEER (Regd)  
SUPERVISOR (Regd)  
OWNER (Regd) SRI UDAY KUMAR AGARWAL

DEVELOPMENT AUTHORITY LOCAL BODY

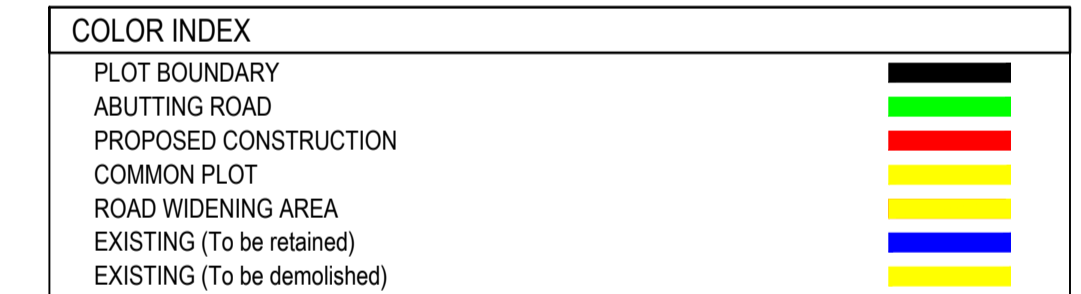

Buildingwise Floor FAR Details

Floor Name	Building Name RESI (UDAY)		Total	
	Proposed Built Up Area (Sq.mt.)	Proposed FAR Area (Sq.mt.)	Total Proposed Built Up Area (Sq.mt.)	Total FAR Area (Sq.mt.)
Ground Floor	69.78	69.78	69.78	69.78
First Floor	71.33	71.33	71.33	71.33
Terrace Floor	0.00	0.00	0.00	0.00
Total :	141.11	141.11	141.11	141.11

Building USE/SUBUSE Details

Building Name	Building Use	Building SubUse	Building Structure
RESI (UDAY)	Residential	Bungalow/ Dwelling / Non Apartment	Non-Highrise

LTP NAME AND SIGNATURE	STRUCTURAL ENG'S NAME AND SIGNATURE	BUILDER NAME AND SIGNATURE	DIGITAL SIGNATURE
ANIL KUMAR CHAUDHARY MADA/ENG/0005/2019			

