

Project Title : 1. Smt. Sangeeta Kumari 2. Sri Satyanarayan Kumar

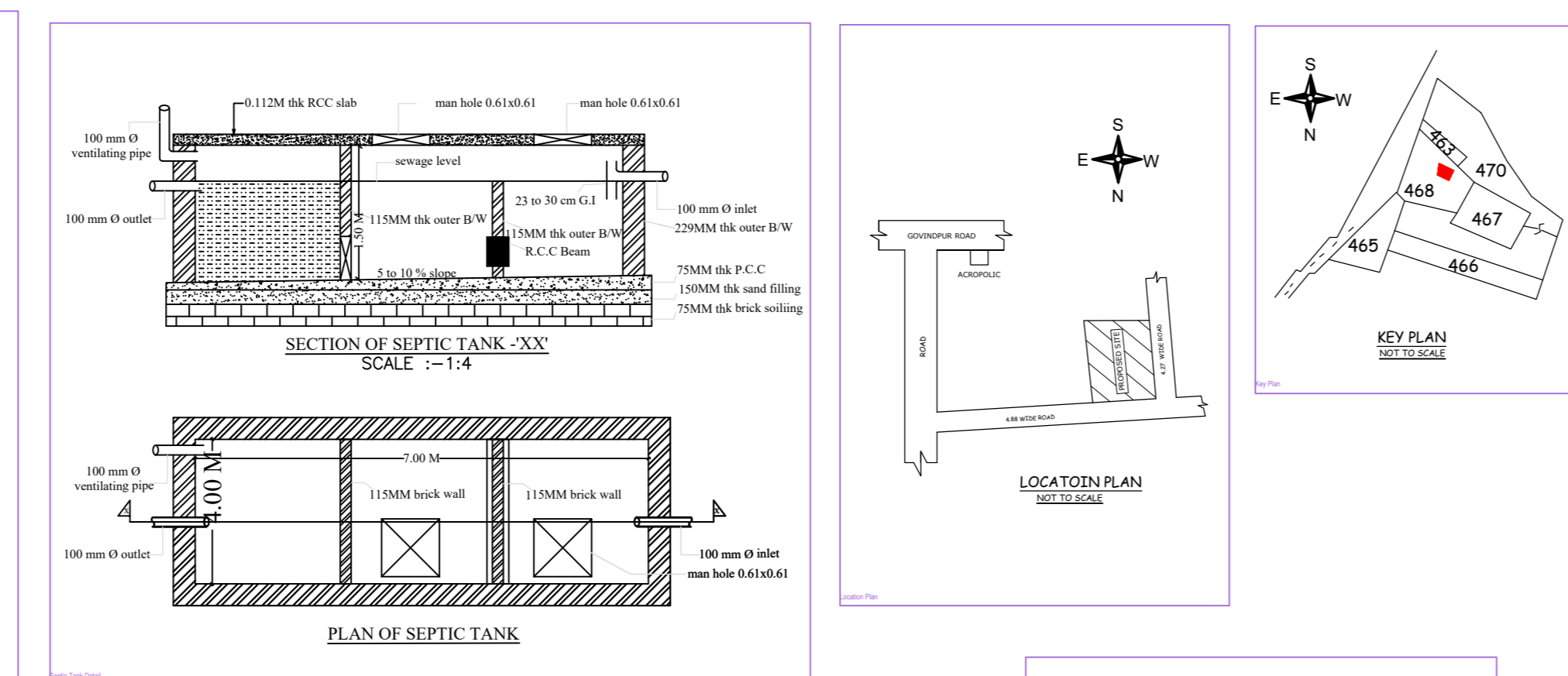
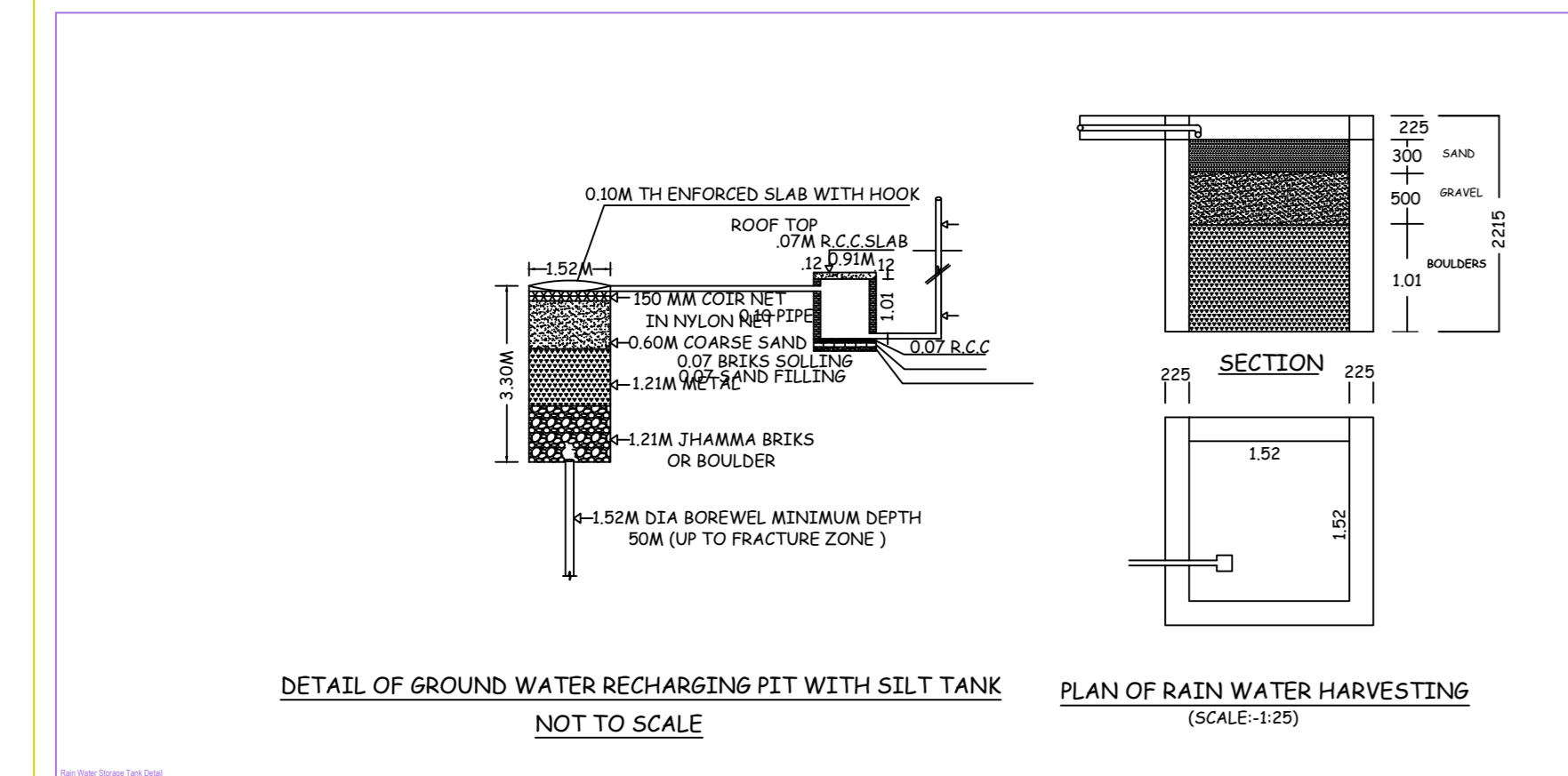
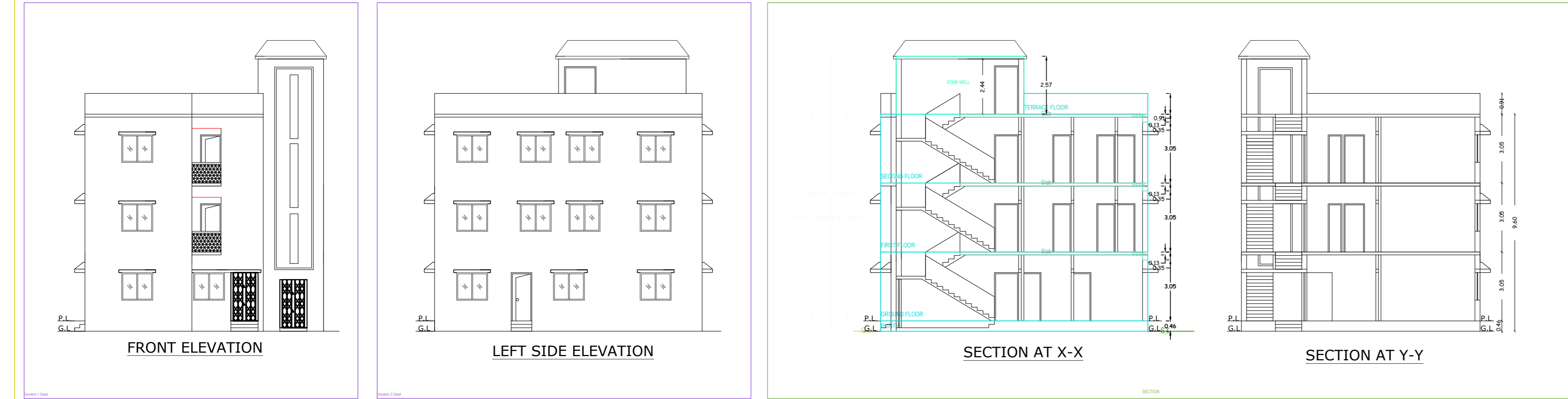

SPECIFICATIONS

FOUNDATION..... CEMENT CONCRETE (R-3.0)
 BRICK WORK IN FOUNDATION & SUPERSTRUCTURE
 FIRST CLASS BRICK WORK IN CEMENT MORTAR (1:4)
 D.P.C..... 25mm D.P.C. IN CEMENT CONCRETE (1:2:4)
 FLOOR..... 25mm I.P.S. OVER 3" P.C.C.
 LINTEL..... 200mm THICK R.C.C. LINTEL (1:1:2:3)
 ROOF..... 125mm THICK R.C.C. ROOF (1:1:2:3)
 STAIR..... RISE - 150mm, TREAD - 250mm
 DOOR..... D - 1.0x2.13, D1 - 0.9x2.13,
 D2 - 0.7x2.13
 WINDOWS..... W - 1.22x2.22,
 VENTILATION..... V - 0.38x0.61
 FALL..... J - 1:22

NOTES

AREA OF LAND..... (AS PER DEED)..... 283.79 Sqm.
 AREA OF LAND..... (AS PER SITE)..... 282.60 Sqm.
 GROUND FLOOR COVERED AREA..... 119.62 Sqm.
 FIRST FLOOR COVERED AREA..... 119.62 Sqm.
 SECOND FLOOR COVERED AREA..... 119.62 Sqm.
 TOTAL COVERED AREA..... 358.86 Sqm.
 % OF PLINTH AREA..... 42.34
 F.A.R..... 1.28

TITLE OF DRAWING

PLAN OF THE PROPOSED RESIDENTIAL BUILDING OF (1) SMT. SANGEETA KUMARI
 W/O SRI SATYANARAYAN KUMAR (2) SRI SATYANARAYAN KUMAR S/O MANI PRASAD
 CHOURASIA ON PART OF C.S. PLOT NO - 470 (OLD), 468 (NEW) UNDER KHATA NO -
 15 (OLD), 08 (NEW) IN MOUZA - GOSIADH, NO - 127, IN THE DISTRICT OF
 DHANBAD, (JHARKHAND).

 SIGNATURE OF OWNER

 SIGNATURE OF ENGINEER

SCALE :- 1:100

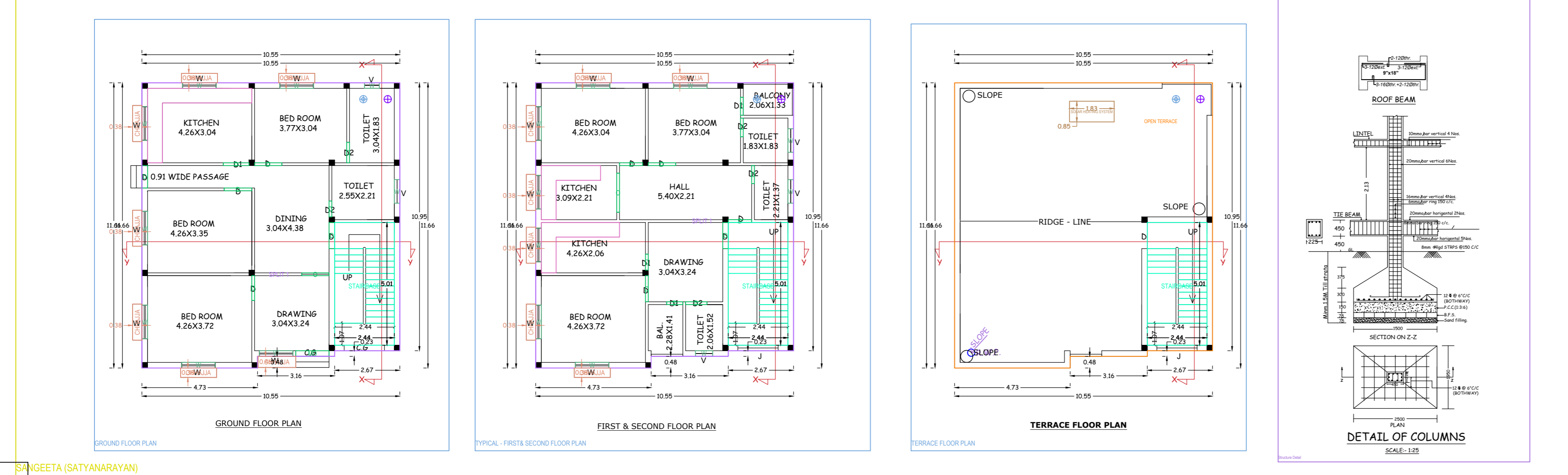

SANGEETA (SATYANARAYAN)

Building SANGEETA (SATYANARAYAN)

Floor Name	Total Built Up Area (Sq.m)	Proposed FAR Area (Sq.m)	Total FAR Area (Sq.m)	Terrace (No.)
Ground Floor	119.62	119.62	119.62	01
First Floor	119.62	119.62	119.62	01
Second Floor	119.62	119.62	119.62	01
Roof Top	119.62	119.62	119.62	01
Total	358.86	358.86	358.86	04
Total Number of Store Building	1	358.86	358.86	01

SCHEDULE OF JOINERY

REQUIREMENT	NAME	LENGTH	HEIGHT	NO.
DOOR	SANGEETA	0.66	2.10	03
DOOR	SANGEETA	0.66	2.10	02
DOOR	SANGEETA	0.74	2.10	04
DOOR	SANGEETA	0.76	2.10	02
DOOR	SANGEETA	0.84	2.10	01
DOOR	SANGEETA	0.88	2.10	02
DOOR	SANGEETA	0.91	2.10	01
DOOR	SANGEETA	0.95	2.10	04
DOOR	SANGEETA	1.02	2.10	01
DOOR	SANGEETA	1.05	2.10	01
DOOR	SANGEETA	1.07	2.10	05
DOOR	SANGEETA	1.12	2.10	01
DOOR	SANGEETA	1.12	2.10	03
DOOR	SANGEETA	1.13	2.10	01
DOOR	SANGEETA	1.38	2.10	01
DOOR	SANGEETA	1.60	2.10	02
Total				34

SCHEDULE OF JOINERY

REQUIREMENT	NAME	LENGTH	HEIGHT	NO.
WINDOW	SANGEETA	0.61	1.20	01
WINDOW	SANGEETA	0.71	1.20	02
WINDOW	SANGEETA	0.97	1.20	05
WINDOW	SANGEETA	1.37	1.20	21
Total				29

Unit/BLA Table for Building - SANGEETA (SATYANARAYAN)

FLOOR	Name	Unit/BLA Type	Unit/BLA Area	Carpet Area	No. of Rooms	No. of Store
GROUND FLOOR	SPLIT 1	FLAT	239.24	229.97	3	1
Total			239.24	229.97	3	1

AREA STATEMENT MINERAL AREA DEVELOPMENT

VERSION NO. 1.0.30
 VERSION DATE: 10/10/2020

PROJECT DETAIL

Project No.: Residential
 Region: JHARKHAND LOCAL BODIES
 District: DHANBAD
 Application Type: Sanction Proposal
 Project Type: Building Permission
 Name of Applicant: Smt. Sangeeta Kumari
 Location: Old Area
 Plot No.: 468
 Village/Block Name: ...
 Ward No.: ...
 Road Name: ...

AREA DETAILS

AREA TYPE	Area (Sq.M)
Net PLOT Area (Gross PLOT Area)	282.64
Development (Gross PLOT Area)	282.64
Development for Balance PLOT Area (Net Gross PLOT Area)	282.64
Total	282.64

COVERED AREA

COVERED AREA TYPE	Area (Sq.M)
Ground Floor	119.62
First Floor	119.62
Second Floor	119.62
Roof Top	119.62
Total	358.86

Color INDEX

Color	Description
Green	Plot Boundary
Red	Plot Boundary
Blue	Proposed Work Coverage Area
Yellow	Existing (To be removed)
Black	Existing (To be retained)

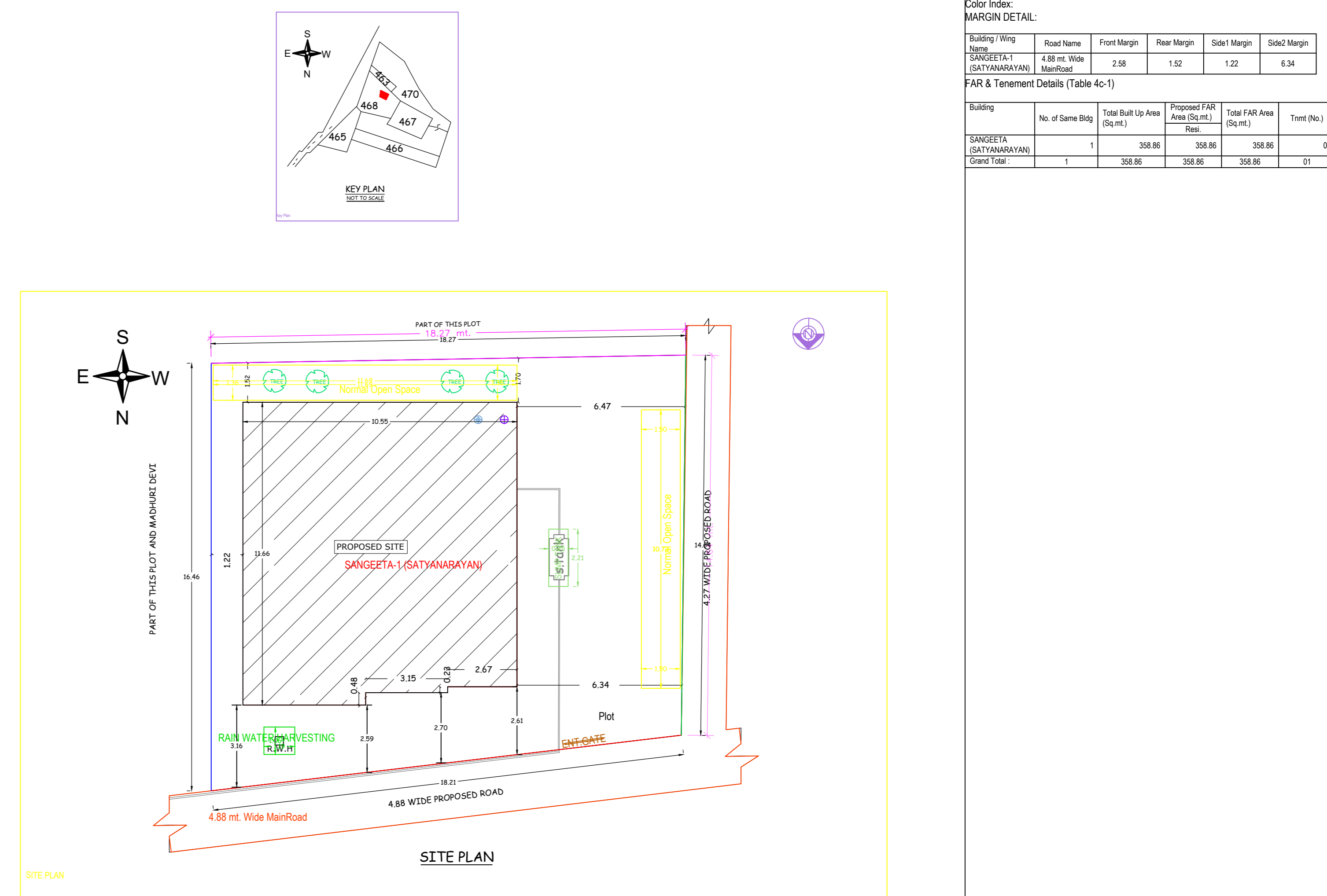

SITE PLAN