

SITE - PLAN  
SCALE 1:100

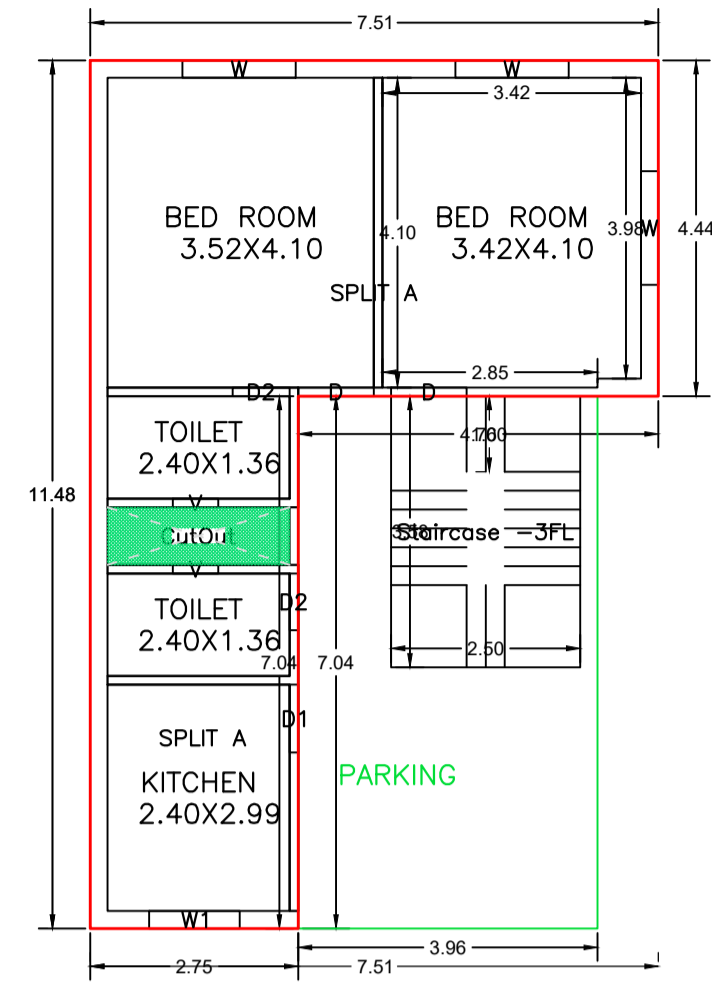

GROUND FLOOR PLAN  
(Proposed)  
SCALE 1:100

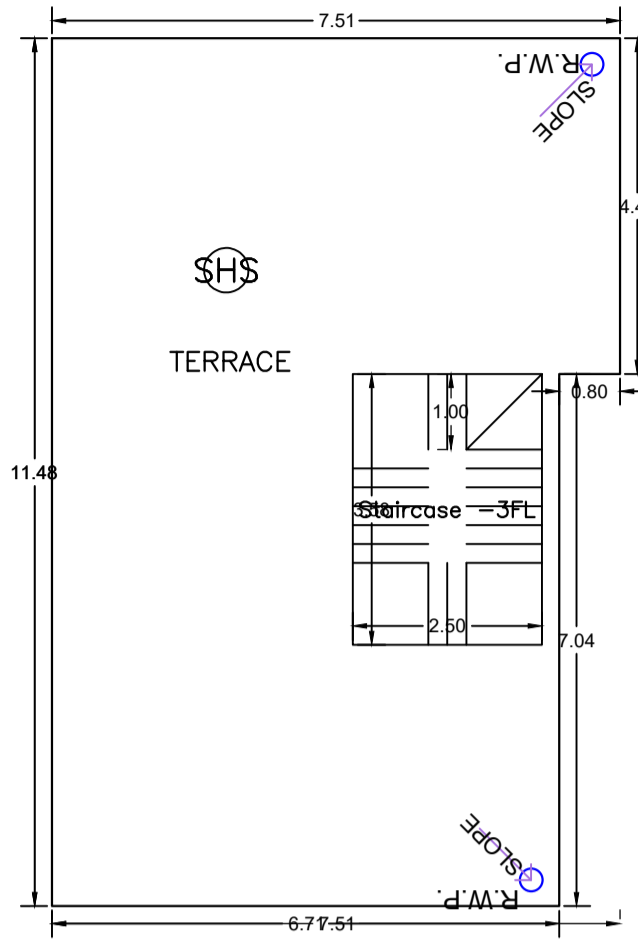

TERRACE FLOOR PLAN  
(SCALE 1:100)

SCHEDULE OF DOOR:

BUILDING NAME	NAME	LENGTH	HEIGHT	NOS
A (RESIDENTIAL)	D2	0.75	2.10	02
A (RESIDENTIAL)	D1	0.90	2.10	01
A (RESIDENTIAL)	D	1.00	2.10	02

SCHEDULE OF WINDOW/VENTILATION:

BUILDING NAME	NAME	LENGTH	HEIGHT	NOS
A (RESIDENTIAL)	V	0.60	0.90	02
A (RESIDENTIAL)	W1	1.20	1.20	01
A (RESIDENTIAL)	W	1.50	1.20	03

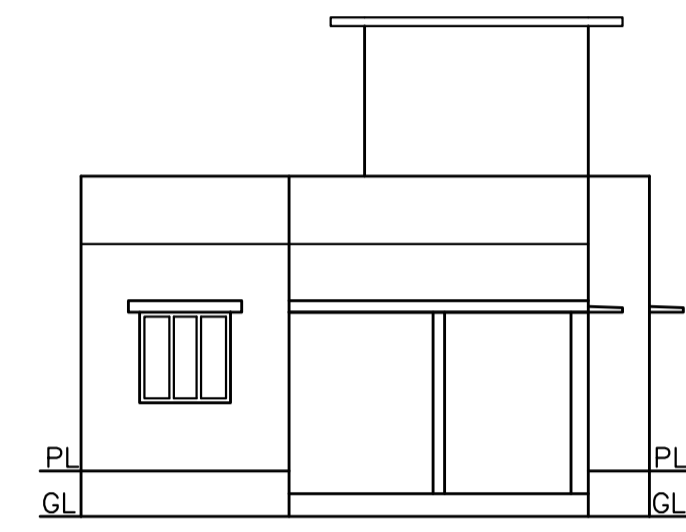

FRONT ELEVATION  
SCALE 1:100

Building :A (RESIDENTIAL)

Floor Name	Gross Builtup Area	Deductions From Gross BUA/Area in Sq.mt.)	Total Built Up Area (Sq.mt.)	Deductions (Area in Sq.mt.)	Proposed FAR Area (Sq.mt.)	Add Area In FAR (Sq.mt.)	Total FAR Area (Sq.mt.)	Total Consumed Additional FAR Area (Sq.mt.)	Tnmt (No.)
Ground Floor	80.61	1.83	78.78	18.92	50.90	8.96	59.86	59.86	01
Terrace Floor	0.00	0.00	0.00	0.00	0.00	0.00	0.00	0.00	00
Total :	80.61	1.83	78.78	18.92	50.90	8.96	59.86	59.86	01
Total Number of Same Buildings :	1								
Total :	80.61	1.83	78.78	18.92	50.90	8.96	59.86	59.86	01

UnitBUA Table for Building :A (RESIDENTIAL)

FLOOR	Name	UnitBUA Type	UnitBUA Area	Carpet Area	No. of Rooms	No. of Tenement
GROUND FLOOR PLAN	SPLIT A	FLAT	44.36	42.08	3	1
	SPLIT A	FLAT	0.00	0.00	2	
Total:	-	-	44.36	42.08	5	1

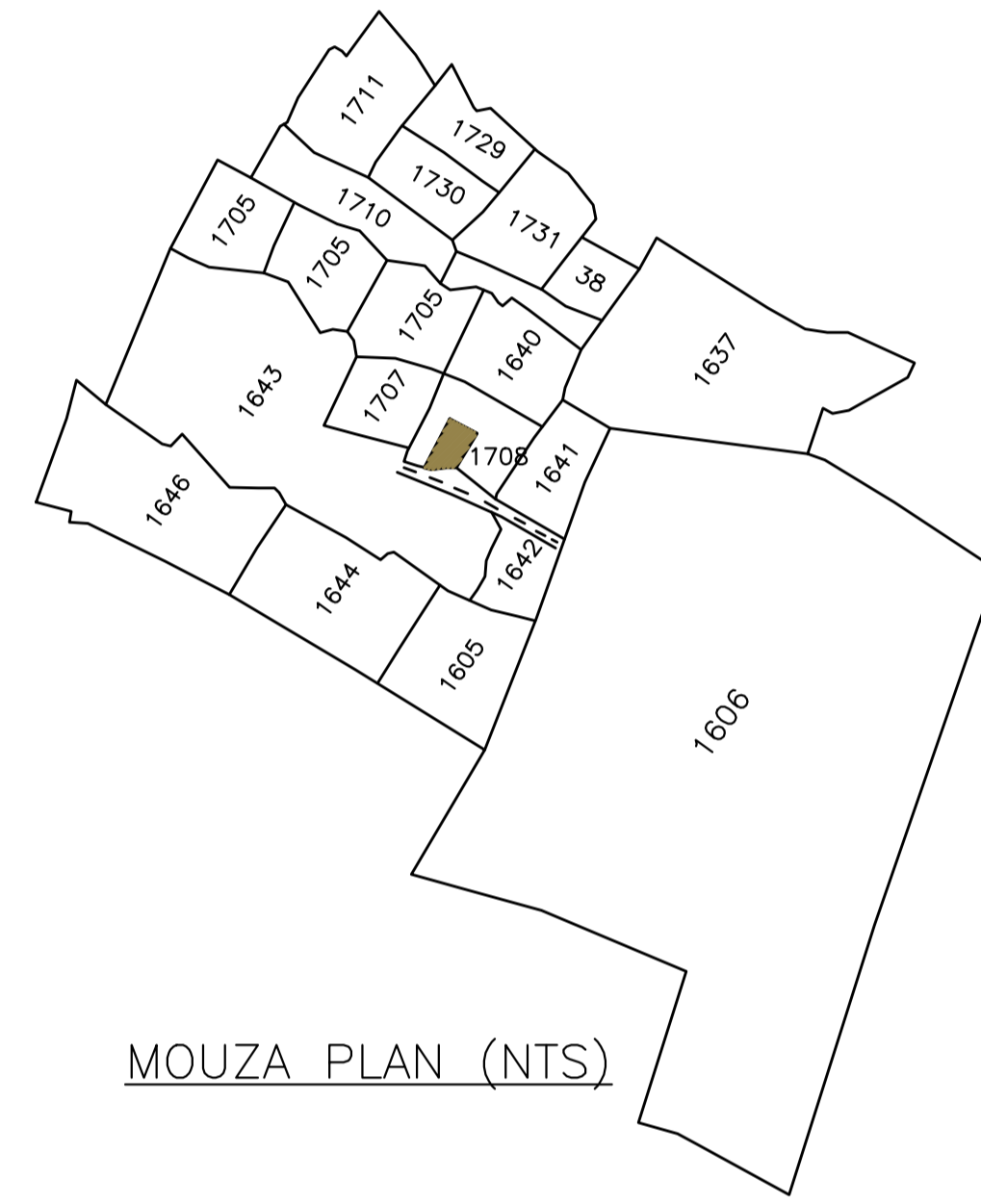

MOUZA PLAN (NTS)

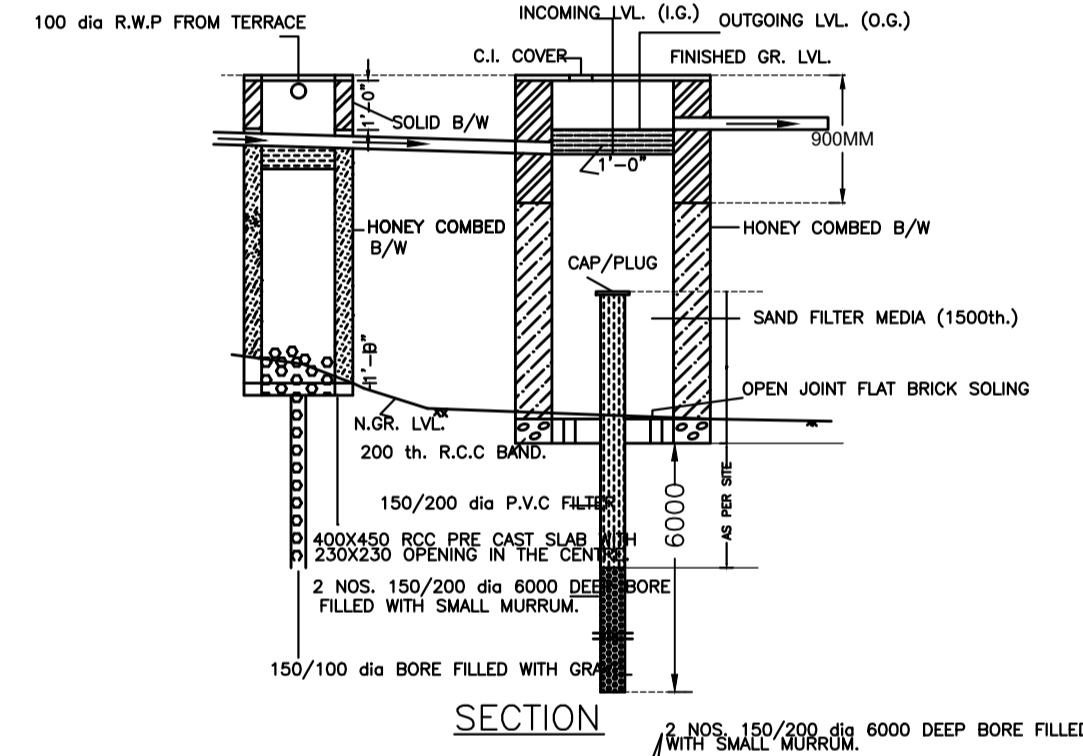

SECTION

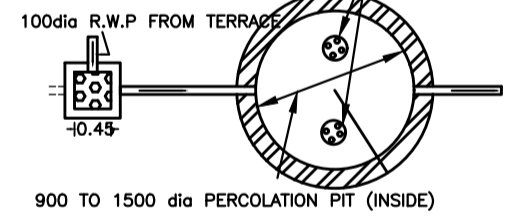

WATER HARVESTING PLAN (NTS)

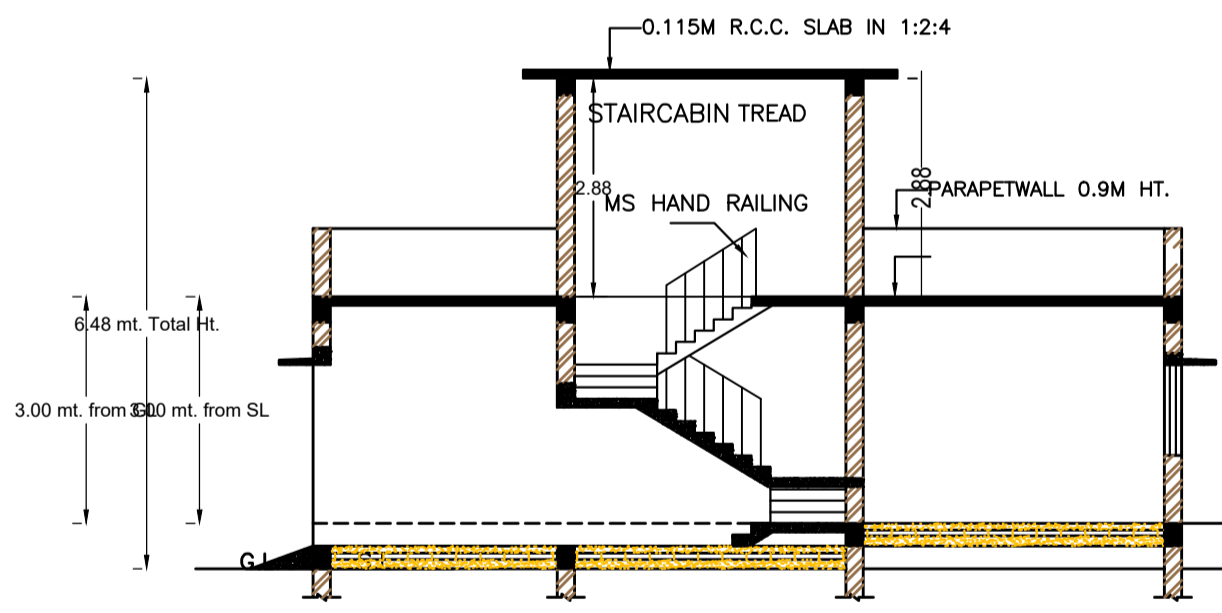

SECTION - AA  
SCALE 1:100

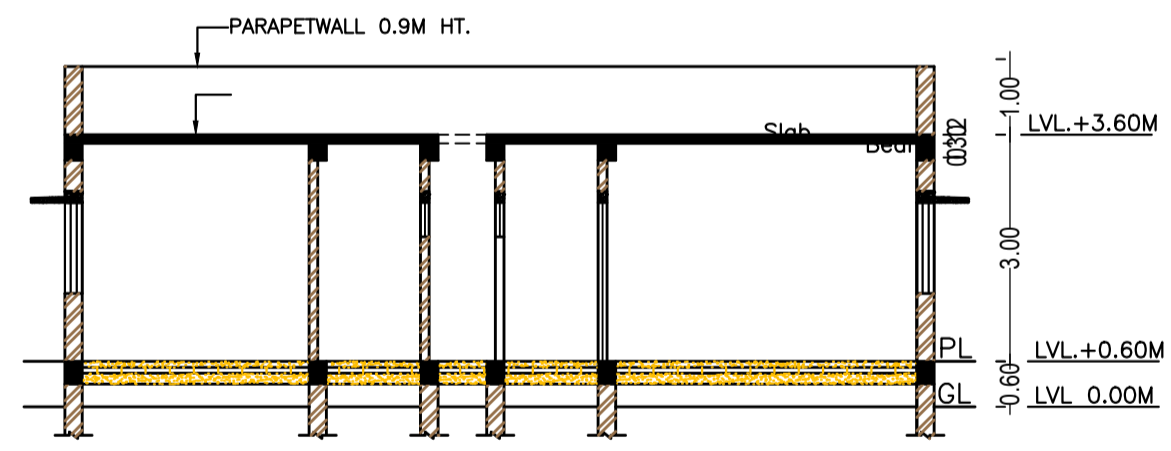

SECTION - BB  
SCALE 1:100

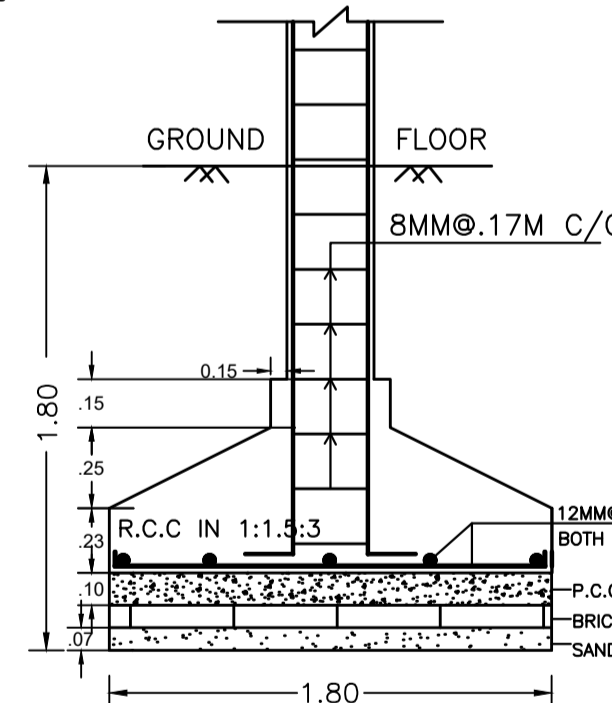

SECTION - CC  
SCALE -1:25

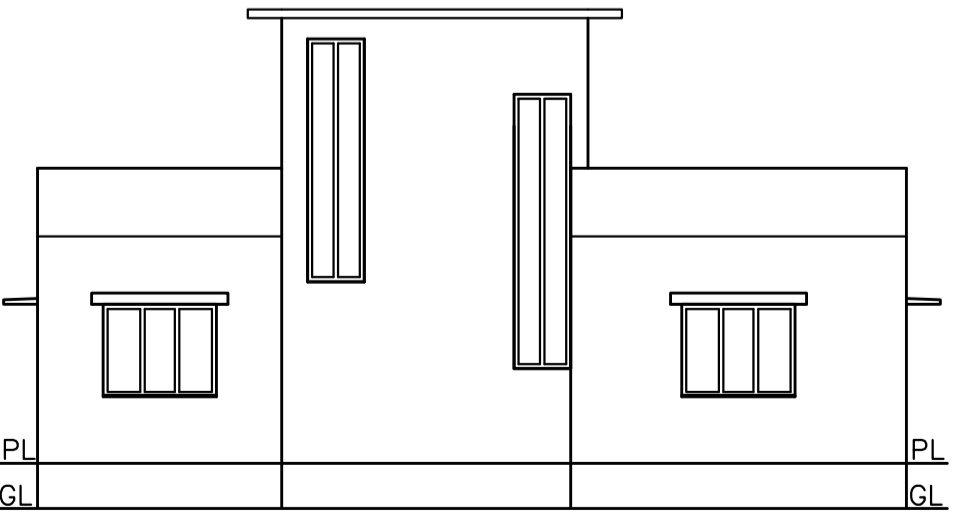

NORTH SIDE ELEVATION  
SCALE 1:100

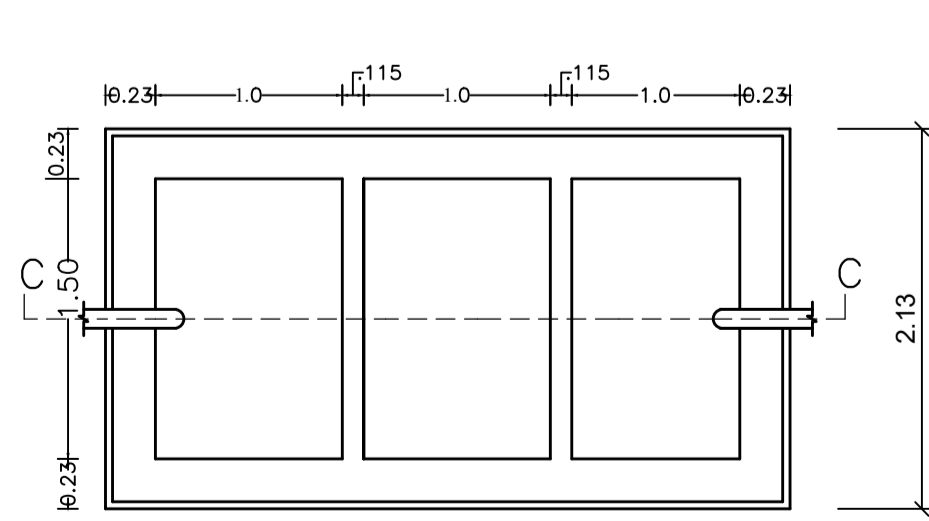

SEPTIC TANK PLAN  
SCALE -1:50

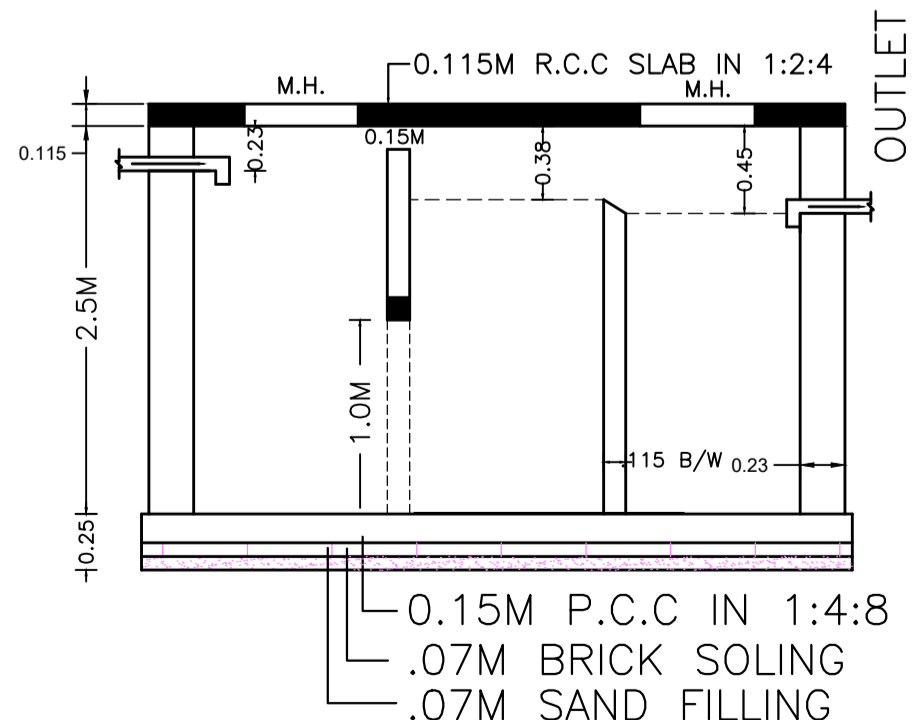

SECTION - SS  
SCALE -1:50

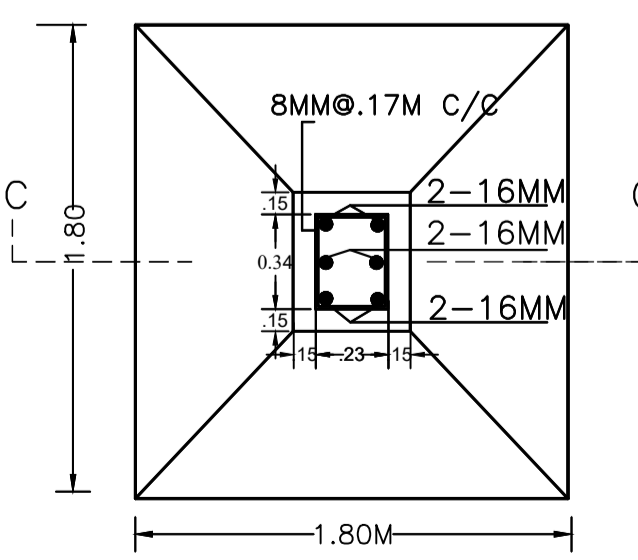

R.C.C. COL. FDN. PLAN  
SCALE -1:25

Proposal Basic Information

Proposal File No.	KANPC/BP/W21/0003/2024
Owner Name	SHARIF ALI
Khata No	31
Plot No	1708
Village Name	Village 1
Use	Residential
SubUse	Bungalow/ Dwelling / Non Apartment

AREA STATEMENT KAPALI NAGAR PANCHAYAT		VERSION NO. : 1.0.69
PROJECT DETAIL:		
Region: JHARKHAND URBAN LOCAL BODIES	Plot Use: Residential	
	Plot SubUse: Bungalow/ Dwelling / Non Apartment	
	PlotNearby/ReligiousStructure: NA	
	Plot/SubPlot No: 1708	
Inward No: KANPC/BP/W21/0003/2024	Plot/SubPlot No: 1708	
Application Type: General Proposal		
Project Type: Building Permission	South -	
Nature of Development: New	East -	
Location of Development Area: Old Area		
AREA DETAILS:		
AREA OF PLOT (Minimum)	(A)	SQ.MT. 132.98
NET AREA OF PLOT(Gross Plot Area - Deduction from Gross Plot area)	(A-Deductions)	
Deduction for Balance Plot Area(from Gross Plot Area)		
Common Plot		16.06
Total		16.06
BALANCE AREA OF PLOT(Net Plot Area - Recreational/Amenity space)	(A-Deductions)	116.92
PLOT AREA FOR COVERAGE(Net Plot Area)		
Plot Area for FAR (Net Plot Area + Road Widening Area)	(A-Deductions)	132.98
COVERAGE CHECK		
Permissible Coverage area ( 70.00 % )		93.09
Proposed Coverage Area ( 59.24 % )		78.78
Total Prop. Coverage Area ( 59.24 % )		78.78
Balance coverage area ( 10.76 % )		
FAR CHECK		
Perm. FAR Area ( 1.500 )		199.47
Total Perm. FAR area		199.47
Residential FAR		50.90
Proposed FAR Area		59.86
Total Proposed FAR Area		59.86
Consumed FAR (Factor)		0.45
		139.61
BUILT UP AREA CHECK		
Total Proposed BuiltUp Area		78.78
ARCHITECT (Regd) EJAZ AHMAD		
ENGINEER (Regd)		
SUPERVISOR (Regd)		
OWNER (Regd) SHARIF ALI		
DEVELOPMENT AUTHORITY LOCAL BODY		

COLOR INDEX	
PLOT BOUNDARY	Black
ABUTTING ROAD	Red
PROPOSED CONSTRUCTION	Green
COMMON PLOT	Yellow
ROAD WIDENING AREA	Blue
EXISTING (To be retained)	Orange
EXISTING (To be demolished)	Purple

Floor Name	Building Name A (RESIDENTIAL)		Total	
	Proposed Built Up Area (Sq.mt.)	Proposed FAR Area (Sq.mt.)	Total Proposed Built Up Area (Sq.mt.)	Total FAR Area (Sq.mt.)
Ground Floor	78.78	59.86	78.78	59.86
Terrace Floor	0.00	0.00	0.00	0.00
Total :	78.78	59.86	78.78	59.86

Building Name	Building Use	Building SubUse	Building Structure
A (RESIDENTIAL)	Residential	Bungalow/ Dwelling / Non Apartment	Non-Highrise

FAR & Tenement Details (Table 4c-1)

Building	No. of Same Bldg	Gross Built Up Area (Sq.mt.)	Deductions From Gross BUA/Area in Sq.mt.)	Total Built Up Area (Sq.mt.)	Deductions (Area in Sq.mt.)	Proposed FAR Area (Sq.mt.)	Add Area In FAR (Sq.mt.)	Total FAR Area (Sq.mt.)	Total Consumed Additional FAR Area (Sq.mt.)	Tnmt (No.)
A (RESIDENTIAL)	1	80.61	1.83	78.78	18.92	50.90	8.96	59.86	59.86	01
Grand Total	1	80.61	1.83	78.78	18.92	50.90	8.96	59.86	59.86	01

LTP NAME AND SIGNATURE	STRUCTURAL ENG'S NAME AND SIGNATURE	BUILDER NAME AND SIGNATURE	DIGITAL SIGNATURE
EJAZ AHMAD KANPC/DFTMN/0006/2020			