

BUILDING WISE FSI STATEMENT

| BUILDING | FSI AREA | | | | | BALCONY | PASSAGE | STAIR | LIFT | TENEMENTS | TOTAL FSI AREA |
|----------|----------|--------|------|-------|-------|---------|---------|-------|------|-----------|----------------|
| | COMM. | RESI. | IND. | SPEC. | | | | | | | |
| A-1 (10) | 0.00 | 109.42 | 0.00 | 0.00 | 11.68 | 0.00 | 14.57 | 0.00 | 1 | 109.42 | |
| Total | 0.00 | 109.42 | 0.00 | 0.00 | 11.68 | 0.00 | 14.57 | 0.00 | 1 | 109.42 | |

FLOOR WISE FSI STATEMENT: A (10)

| FLOORS | FSI AREA | | | | | BALCONY | PASSAGE | STAIR | LIFT | TENEMENTS | TOTAL FSI AREA |
|--------------------|----------|--------|------|-------|-------|---------|---------|-------|------|-----------|----------------|
| | COMM. | RESI. | IND. | SPEC. | | | | | | | |
| PARAPETWALLOUTLINE | 0.00 | 0.00 | 0.00 | 0.00 | 0.00 | 0.00 | 0.00 | 0.00 | 0.00 | 0 | 0.00 |
| SECOND FLOOR | 0.00 | 27.33 | 0.00 | 0.00 | 4.44 | 0.00 | 5.17 | 0.00 | 0 | 0 | 27.33 |
| FIRST FLOOR | 0.00 | 38.83 | 0.00 | 0.00 | 7.24 | 0.00 | 4.70 | 0.00 | 0 | 0 | 38.83 |
| GROUND FLOOR | 0.00 | 43.27 | 0.00 | 0.00 | 0.00 | 0.00 | 4.70 | 0.00 | 1 | 1 | 43.27 |
| Total | 0.00 | 109.42 | 0.00 | 0.00 | 11.68 | 0.00 | 14.57 | 0.00 | 1 | 1 | 109.42 |

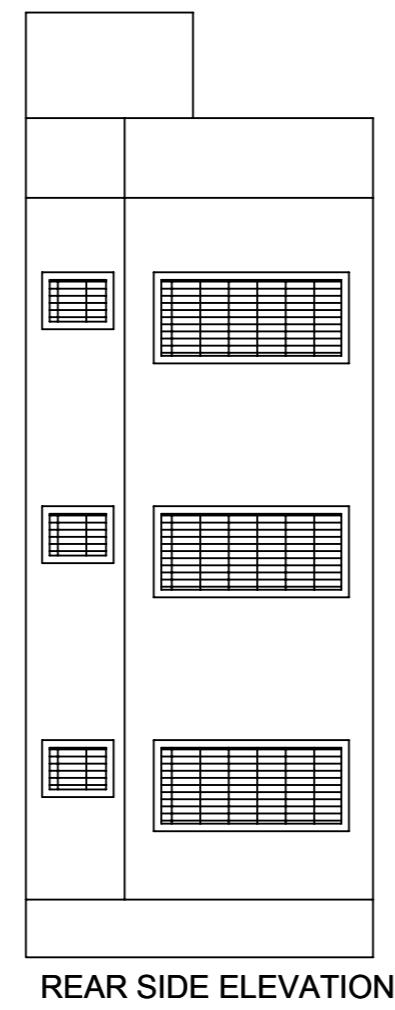
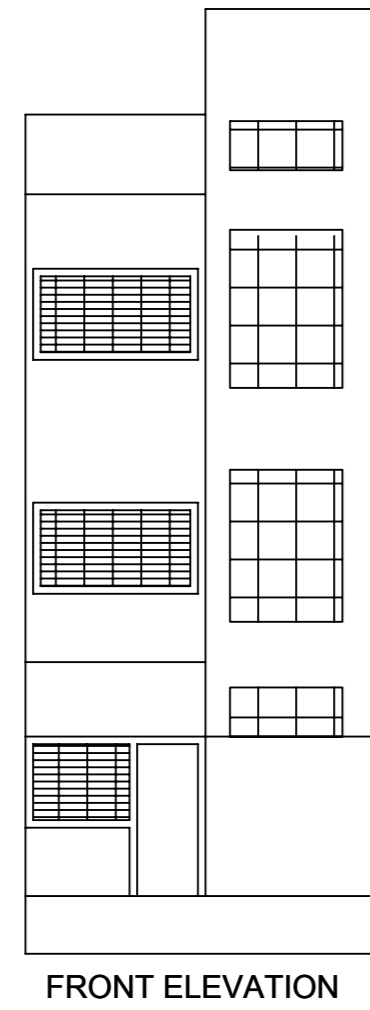
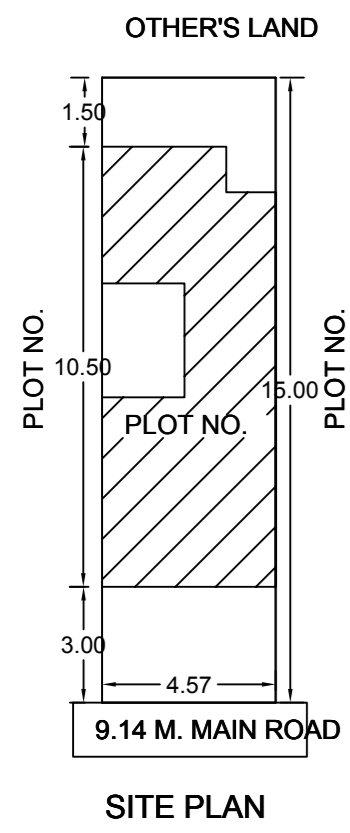
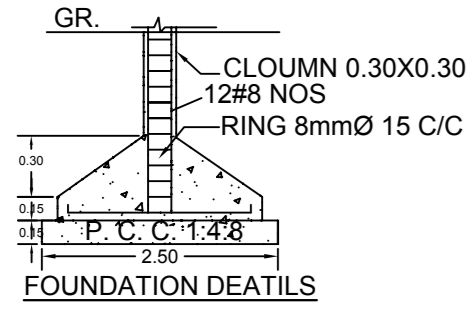

GROUND FLOOR PLAN

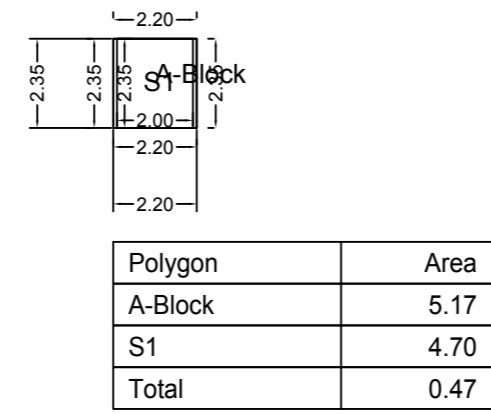

GROUND FLOOR PLAN

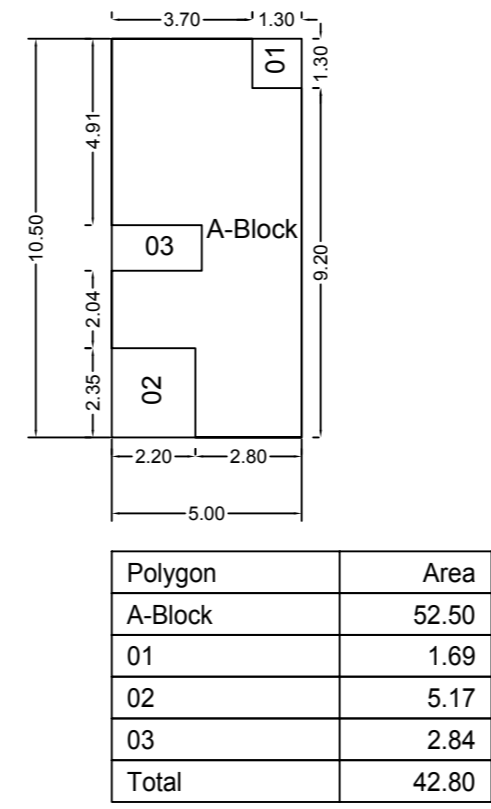

FIRST FLOOR PLAN

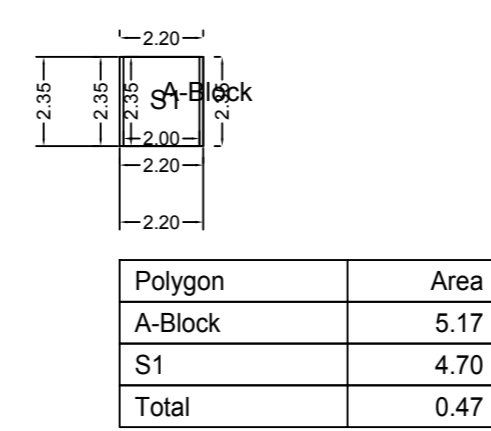

FIRST FLOOR PLAN

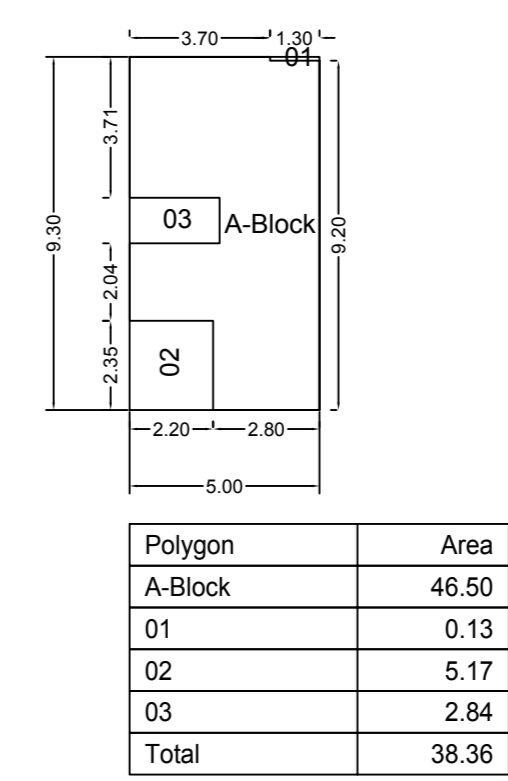

SECOND FLOOR PLAN

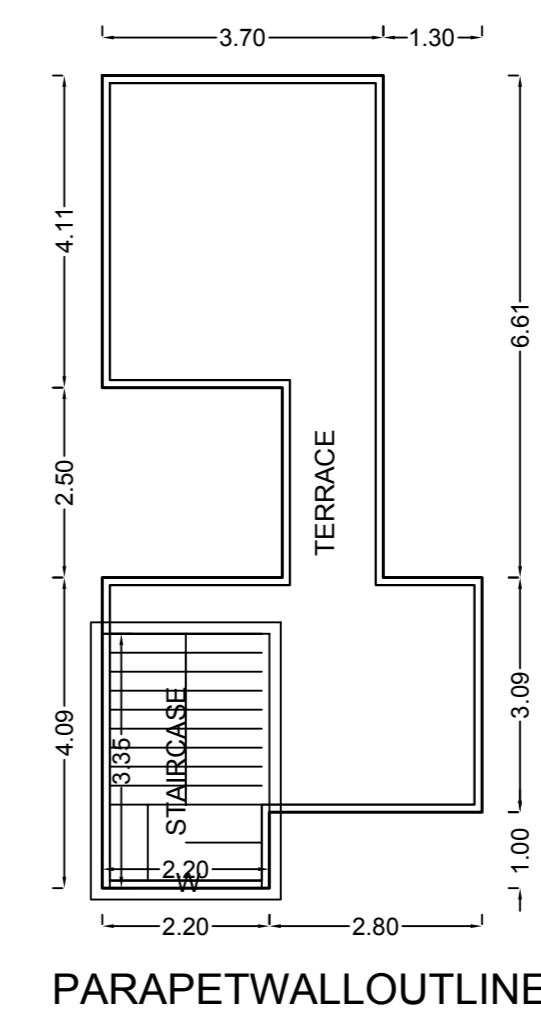
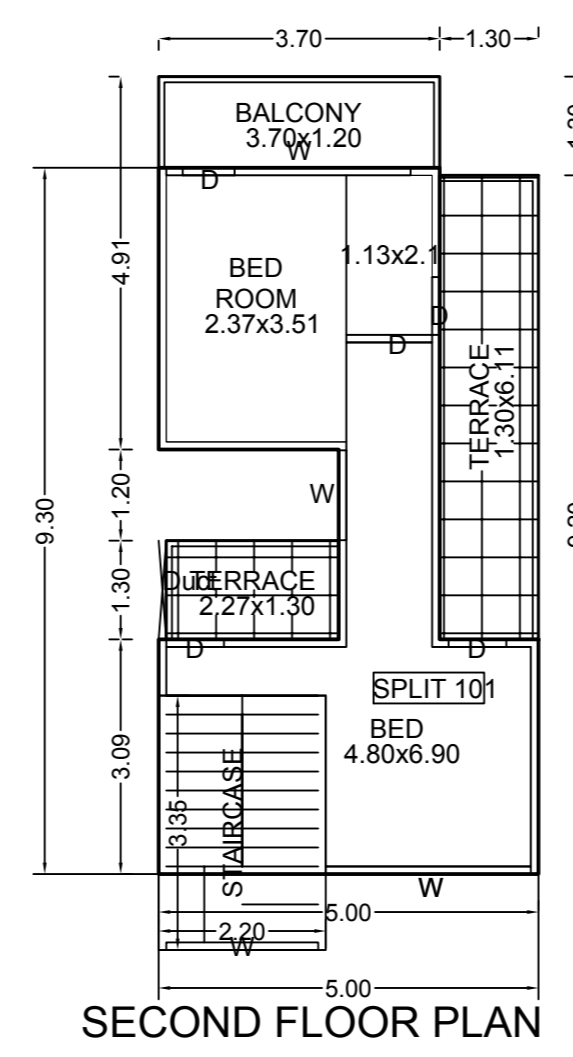
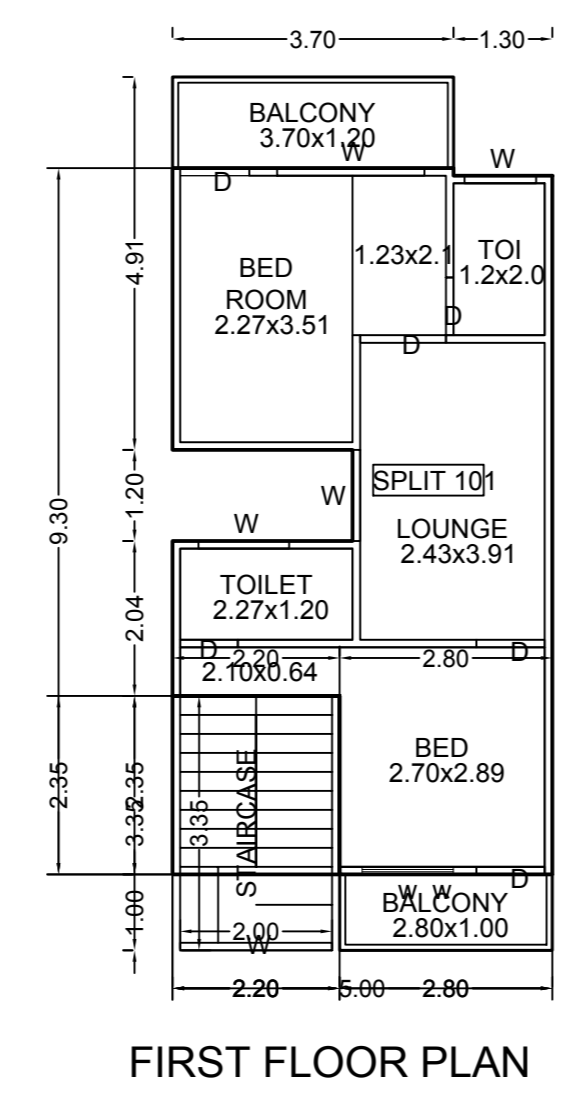
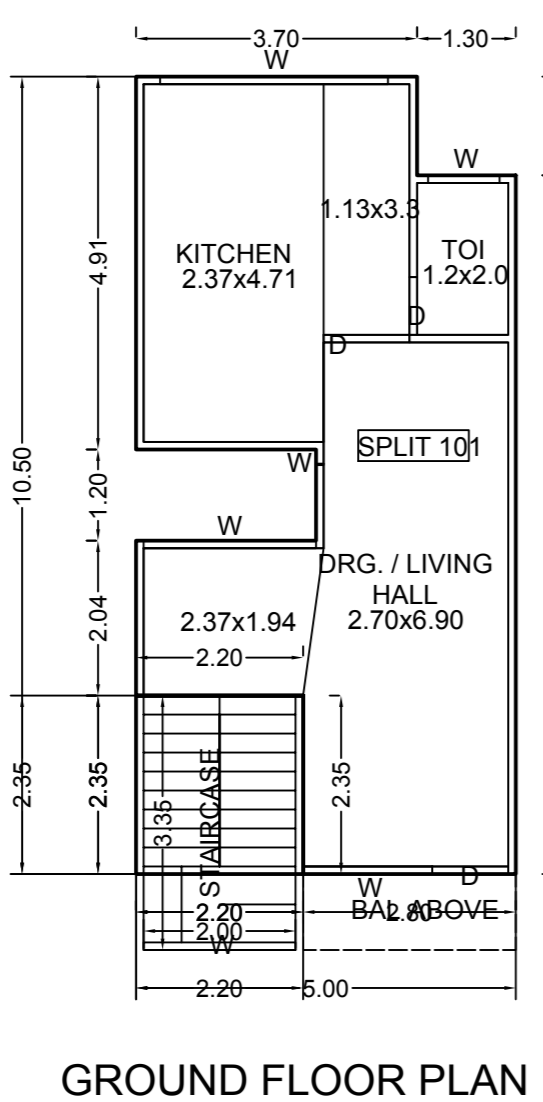
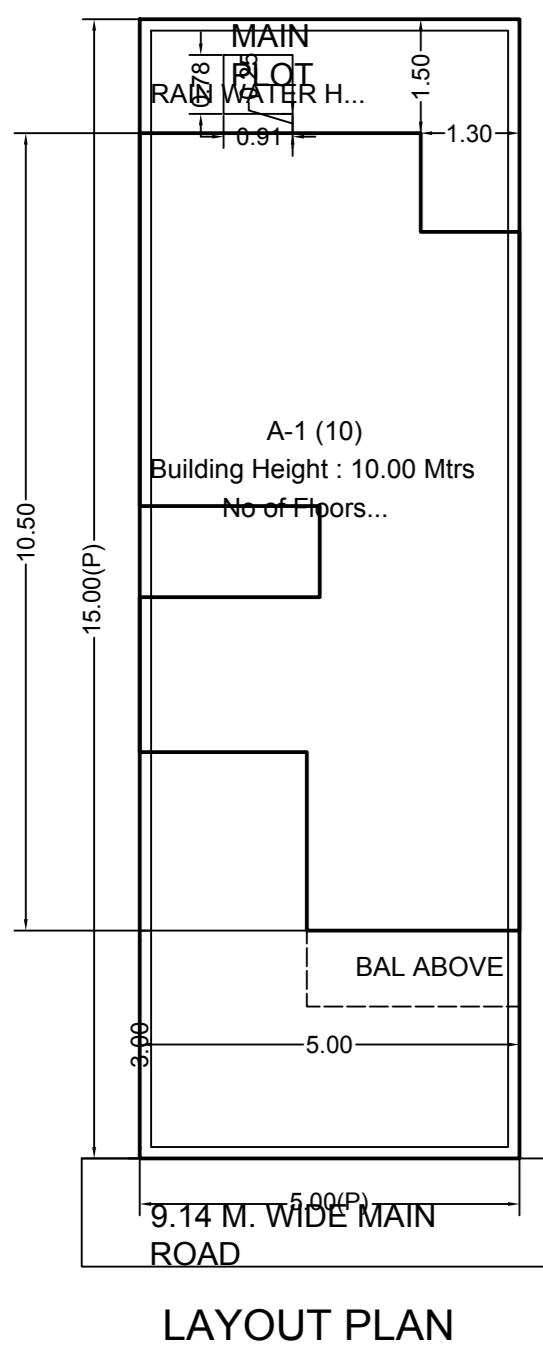
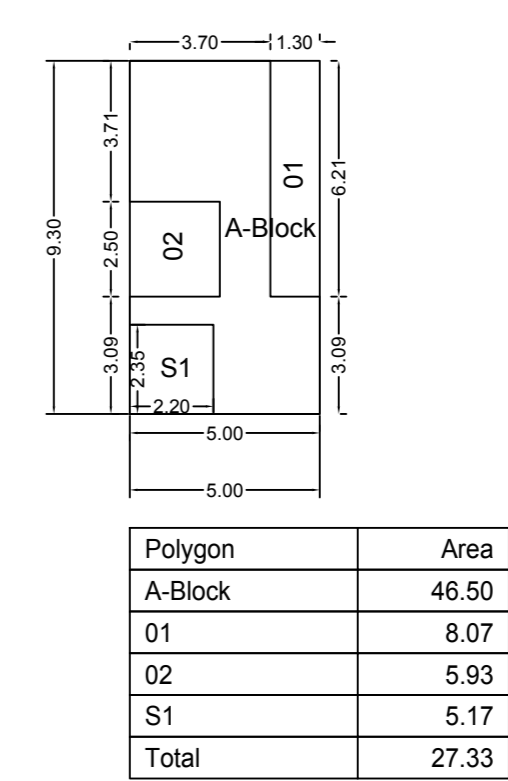

SEAL OF APPROVAL

| AREA STATEMENT | SQ.M. |
|--|----------------|
| 1. AREA OF PLOT | 75.00 |
| 2. DEDUCTIONS (From Gross Plot Area) | |
| (a) ROAD SETBACK AREA (RW) | 0.00 |
| (b) OTHERS | 0.00 |
| Total (a+b) | 0.00 |
| 3. BALANCE PLOT AREA | 75.00 |
| 4. PERMISSIBLE F A R FACTOR | 1.5000 |
| PERMISSIBLE BUILT UP AREA | 112.50 |
| 5. SPECIAL CASES F A R | 0.00 |
| 6. TOTAL PERMISSIBLE BUILT UP AREA | 112.50 |
| 7. PROPOSED AREAS | |
| (a) PROPOSED RESIDENTIAL AREA | 109.42 |
| (b) PROPOSED COMMERCIAL AREA | 0.00 |
| (c) PROPOSED INDUSTRIAL AREA | 0.00 |
| (d) PROPOSED SPECIAL USE AREA | 0.00 |
| TOTAL PROPOSED AREA (a+b+c+d) | 109.42 |
| 8. EXCESS SERVICE AREA | 0.00 |
| 9. EXISTING BUILT UP AREA | 0.00 |
| 10. OTHERS (SUBSTRUCTURE/PROJECTIONS) | 0.00 |
| 11. TOTAL BUILT UP AREA PROPOSED (7 to 10) | 109.42 |
| 12. CONSUMED FAR | 1.4590 |
| 13. TOTAL SLAB AREA | 135.68 |
| 14. COVERAGE AREA | |
| PERMISSIBLE | 45.00 (60.00%) |
| PROPOSED | 43.27 (57.69%) |

SPECIFICATIONS

CERTIFICATE OF AREA

CERTIFIED THAT I HAVE SURVEYED THE PLOT UNDER REFERENCE ON ... AND THAT THE DIMENSIONS OF THE SIDES, ETC. OF THE PLOT STATED ON THE PLAN ARE AS MEASURED ON THE SITE AND THE AREA, SO WORKED OUT IS ... SQUARE METRES AND TALLIES WITH THE AREA STATED IN THE DOCUMENT OF OWNERSHIP / TOWN PLANNING SCHEME RECORDS.

SIGN OF ARCHITECT/ENGINEER/SUPERVISOR

LEGEND

| | |
|-----------------------------------|-------|
| PLOT BOUNDARY SHOWN THICK BLACK | ————— |
| PROPOSED WORK SHOWN RED FILLED IN | ————— |
| DRAINAGE LINE SHOWN RED DOTTED | ————— |
| WATERLINE SHOWN BLUE DOTTED | ————— |
| EXISTING TO BE RETAINED HATCHED | ————— |
| DEMOLISHION SHOWN HATCHED YELLOW | ————— |

PROJECT INFORMATION

PLOT NO.: _____ WARD : _____
ZONE : _____ COLONY: _____
INDORE, (M.P.)

OWNER'S NAME AND SIGNATURE

BUILDER'S INFORMATION

NAME : _____
LICENSE NO.: _____
B.O. NAME : _____ B. I. NAME : _____
PREVIOUS SANCTION MEMO NO.: _____
ARCHITECT NAME

| JOB NO. | DRG.NO. | SCALE | DRAWN BY | CHECKED BY |
|---------------------|---------|-------|----------|------------|
| | | 1:100 | | |
| INWARD NO(5) 5.0X15 | | | DATE | 31-10-2012 |
| KEY NO 694 | | | SHEET NO | 1 / 1 |